



CC SHT

Ventilatori assiali intubati ad alta efficienza High efficiency duct axial fans



sez.
1.2

EN 12101-3:2015

Applus⁺

F300/120 - F400

Certificato | Certificate

0370 - CPD - 1358

0370 - CPD - 1359

CC SHT aspiratori assiali | axial fans

DESCRIZIONE

Ventilatori assiali intubati ad alta efficienza per applicazioni canalizzate progettati e omologati per l'evacuazione di fumi ad alta temperatura. Specificatamente progettati in una gamma che consente di soddisfare le prestazioni richieste nei regolamenti tecnici di prevenzione incendi per la progettazione e costruzione di attività commerciali e nella ventilazione antincendio per l'edilizia, come illustrato nella UNI 9494.

La serie è idonea al funzionamento alla temperatura di +60°C ed è certificata F300/120 F400 (ad esclusione delle versioni 2 poli, certificate F300/120) secondo la Normativa EN 12101-3:2015.

COSTRUZIONE

- Cassa in lamiera d'acciaio, con flange di fissaggio a norma UNI ISO 13351:2009. Verniciata a polveri epossidiche.
- Girante ad altissima efficienza in lega di alluminio dal profilo ottimizzato che garantisce resistenza ad alte temperature. Bilanciata secondo ISO 21940-11:2017. Angolo di calettamento variabile da fermo.
- Esecuzione 4 (accoppiamento diretto con girante a sbalzo) e flusso aria da girante a motore.

MOTORE

Motore asincrono trifase a norme internazionali IEC 60034, IEC 60072, EMC 2014/30/UE, LVD 2014/35/UE e marcato CE IP55, classe F o H, omologato F200, F300 o F400 secondo la Direttiva Europea EN 12101-3:2015. Asse orizzontale standard (altri orientamenti su richiesta).

ACCESSORI

- CCr - Rete di protezione
- CCbo - Boccaglio in aspirazione e in mandata
- CCsa/sb - Silenziatore cilindrico con o senza ogiva
- Supporti antivibranti
- CCpro - Prolunga
- CCst - Staffe di sostegno
- Ccga-HT - Giunto flessibile antivibrante
- BDD - Serranda di non ritorno
- CCf - Controflangia
- CCfc - Controflangia con collare
- CCot - Terminale con rete
- Morsettiere esterna alta temperatura, montata.

DESCRIPTION

High efficiency duct axial fans designed for high temperature smoke extraction. CC SHT fans are specifically dimensioned in a standard range suitable for the performance ratings which are normally requested by the building ventilation fire smoke exhaust rules.

The series is suitable for running at the temperature of +60°C and is CE certified F300/120 F400 (except 2 poles versions, certified F300/120) according to EN 12101-3:2015.

CONSTRUCTION

- Short casing in steel sheet, with fixing flanges manufactured according to UNI ISO 13351:2009 standard. Protected against atmospheric agents by epoxy paint.
- High efficiency axial impeller in die-cast aluminium with aerofoil profile blades, totally made. Balanced according to ISO 21940-11:2017. Variable pitch angle in still position.
- Execution 4 (with impeller directly coupled to motor with feet) and airflow from impeller to motor.

MOTOR

Asynchronous three-phase motors according to international standards IEC 60034, IEC 60072, EMC 2014/30/UE, LVD 2014/35/UE, CE marked, IP 55, class F or H, F200, F300 or F400 certified according to the European Directive EN 12101-3:2015. Horizontal axis as standard (other orientations on request).

ACCESSORIES

- CCr - Protection guard
- CCbo - Inlet / outlet cone
- CCsa/sb - Cylindrical silencer
- Antivibration mounts
- CCpro - Long casing extension
- CCst - Support feet
- Ccga-HT - Flexible antivibration connector
- BDD - Backdraught damper
- CCf - Counter-flange
- CCfc - Counter-flange with collar
- CCot - Outlet terminal
- External terminal box for high temperature, assembled.

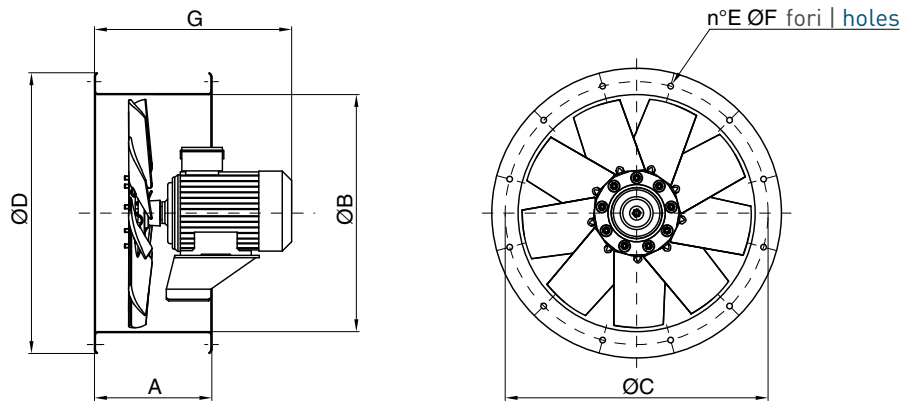

CC SHT

TIPO TYPE	A	ØB	ØC	ØD	E	ØF	G	Kg
CC SHT 310	200	310	355	395	8	10	380	22
CC SHT 350	200	350	395	446	8	10	380	25
CC SHT 400	230	400	450	496	8	12	430	30
CC SHT 450	230	450	500	546	8	12	430	38
CC SHT 500	250	500	560	598	12	12	440	39
CC SHT 560	250	560	620	658	12	12	440	42
CC SHT 630	250	630	690	730	12	12	470	52
CC SHT 710	250	710	770	810	16	12	520	66
CC SHT 800	350	800	860	910	16	12	580	125
CC SHT 900	350	900	970	1030	16	16	680	180
CC SHT 1000	350	1000	1070	1130	16	16	750	215

Pesi indicativi | Indicative weights

PRESTAZIONI | PERFORMANCE

CC SHT

Le prestazioni aerauliche sono rilevate in conformità alla norma EN ISO 5801/AMCA 210 con densità dell'aria standard avente peso specifico 1,2 Kg/m³. Alimentazione 230V/1Ph/50Hz o 400V/3Ph/50Hz. Air performances measured according to EN ISO 5801 / AMCA 210 standard with air density with 1.2 Kg/m³ specific weight. Power supply 230V/1Ph/50Hz or 400V/3Ph/50Hz.

Lp Livello di pressione sonora rilevato in condizioni di campo libero, propagazione sferica, categoria di misura D a norma EN ISO 13349, nel punto di massimo rendimento, alla distanza di 3 m dalla cassa e si presenta solo per fini comparativi. Sound pressure level measured in free field, spherical propagation, measurement category D according to EN ISO 13349, at the maximum output rate, at a distance of 3 m from inlet side. Data given only for comparative purpose.

Lw Livello di potenza sonora ottenuto secondo norma ISO 3746. Tolleranza +/- 3 dB(A). Sound power level according to ISO3746. Tolerance +/- 3 dB(A)

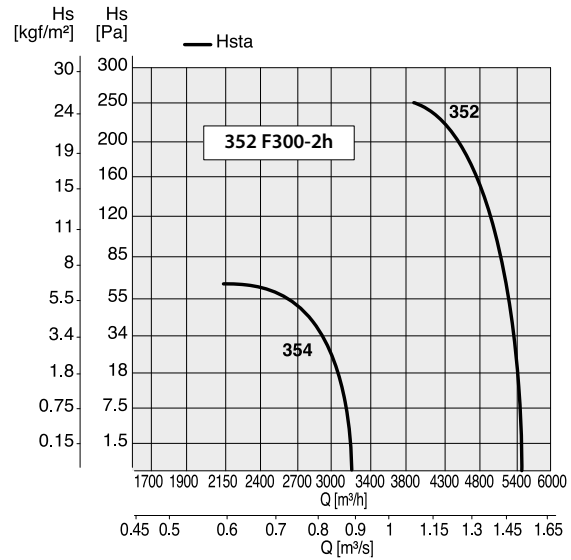
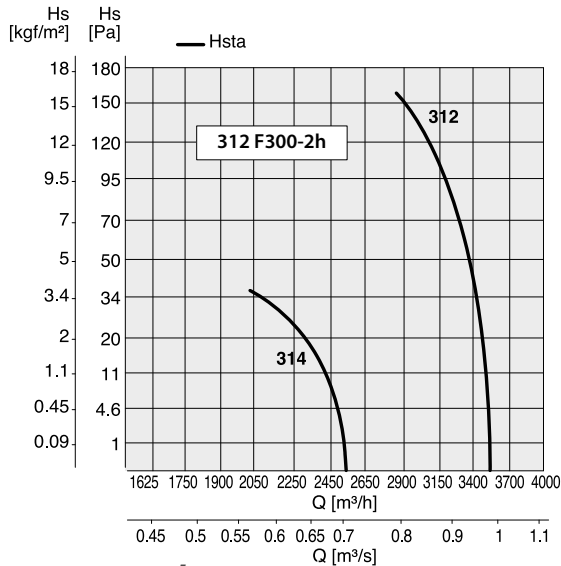

CC SHT 312 / 314

Code F300/120	Code F400	Tipo Type	Mod. Model	U P	rpm	Pm (kW)	In (A)	IP/CL	Mot. (Gr)	IE3	Lp dB(A)
1CS3001	(1)	CC SHT	312	T 2	2790	0,75	1,69	55/F	80	✓	67
1CS3000	1CS4000		314	T 4	1430	0,55	1,23	55/F	80	-	51

(1) Modello 2 poli F400 non disponibile | Model 2p F400 not available

CC SHT 352 / 354

Code F300/120	Code F400	Tipo Type	Mod. Model	U P	rpm	Pm (kW)	In (A)	IP/CL	Mot. (Gr)	IE3	Lp dB(A)
1CS3003	(1)	CC SHT	352	T 2	2790	0,75	1,69	55/F	80	✓	73
1CS3002	1CS4001		354	T 4	1430	0,55	1,23	55/F	80	-	55

(1) Modello 2 poli F400 non disponibile | Model 2p F400 not available

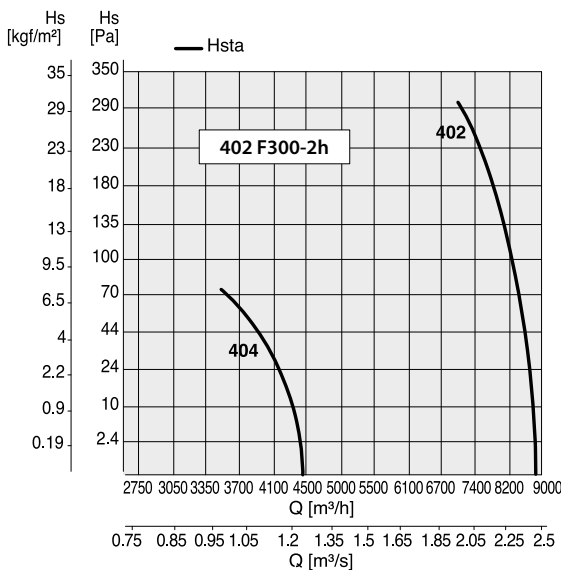

CC SHT 402 / 404

Code F300/120	Code F400	Tipo Type	Mod. Model	U P	rpm	Pm (kW)	In (A)	IP/CL	Mot. (Gr)	IE3	Lp dB(A)
1CS3005	(1)	CC SHT	402	T 2	2790	1,5	3,20	55/F	80	✓	76
1CS3004	1CS4002		404	T 4	1430	0,55	1,23	55/F	80	-	59

(1) Modello 2 poli F400 non disponibile | Model 2p F400 not available

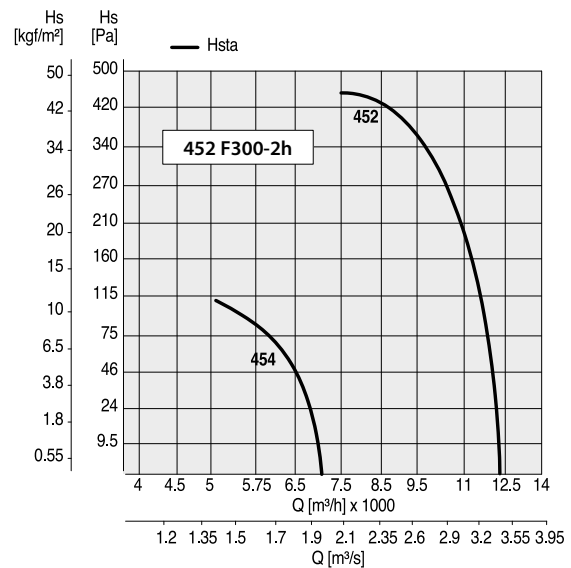

CC SHT 452 / 454

Code F300/120	Code F400	Tipo Type	Mod. Model	U P	rpm	Pm (kW)	In (A)	IP/CL	Mot. (Gr)	IE3	Lp dB(A)
1CS3007	(1)	CC SHT	452	T 2	2840	2,20	4,43	55/F	90	✓	80
1CS3006	1CS4003		454	T 4	1430	0,55	1,23	55/F	80	-	63

(1) Modello 2 poli F400 non disponibile | Model 2p F400 not available

sez. 1.2

CC SHT aspiratori assiali | axial fans

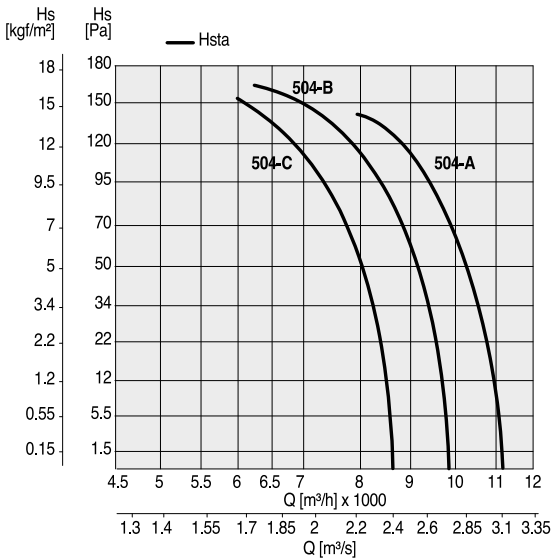

CC SHT 504

Code F300/120	Code F400	Tipo Type	Mod. Model	U	P	rpm	Pm (kW)	In (A)	IP/CL	Mot. (Gr)	IE3	Lp dB(A)
1CS3008	1CS4004		504 A	T	4	1440	1,10	2,35	55/F	90	✓	66
1CS3009	1CS4005	CC SHT	504 B	T	4	1415	0,75	1,66	55/F	80	✓	63
1CS3010	1CS4006		504 C	T	4	1430	0,55	1,23	55/F	80	-	64

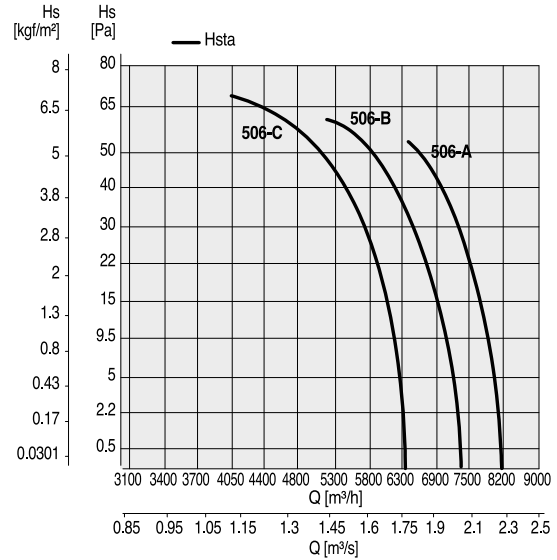

CC SHT 506

Code F300/120	Code F400	Tipo Type	Mod. Model	U	P	rpm	Pm (kW)	In (A)	IP/CL	Mot. (Gr)	IE3	Lp dB(A)
1CS3011	1CS4007		506 A	T	6	930	0,37	0,98	55/F	80	-	65
1CS3012	1CS4008	CC SHT	506 B	T	6	930	0,37	0,98	55/F	80	-	63
1CS3013	1CS4009		506 C	T	6	930	0,37	0,98	55/F	80	-	61

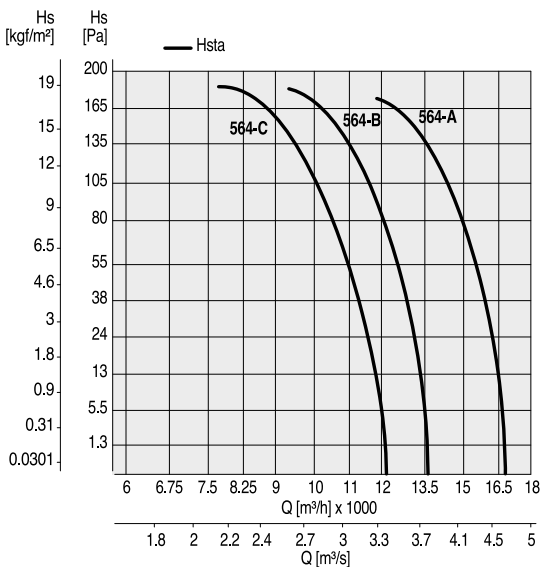

CC SHT 564

Code F300/120	Code F400	Tipo Type	Mod. Model	U	P	rpm	Pm (kW)	In (A)	IP/CL	Mot. (Gr)	IE3	Lp dB(A)
1CS3014	1CS4010		564	T	4	1420	1,50	3,17	55/F	90	✓	70
1CS3015	1CS4011	CC SHT	564	T	4	1440	1,10	2,35	55/F	90	✓	67
1CS3016	1CS4012		564	T	4	1415	0,75	1,66	55/F	80	✓	67

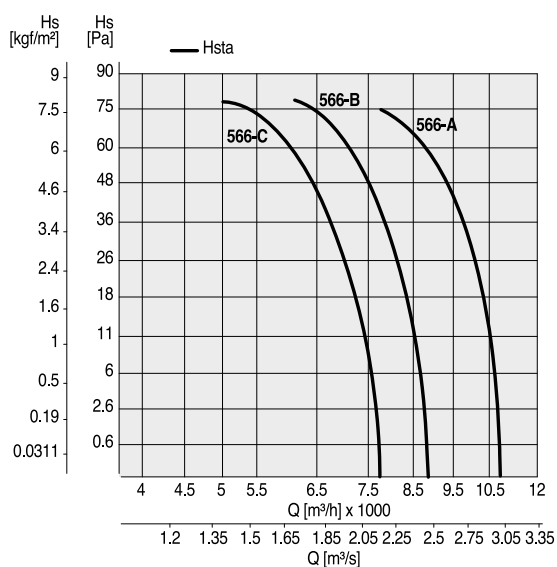

CC SHT 566

Code F300/120	Code F400	Tipo Type	Mod. Model	U	P	rpm	Pm (kW)	In (A)	IP/CL	Mot. (Gr)	IE3	Lp dB(A)
1CS3017	1CS4013		566 A	T	6	930	0,37	0,98	55/F	80	-	64
1CS3018	1CS4014	CC SHT	566 B	T	6	930	0,37	0,98	55/F	80	-	64
1CS3019	1CS4015		566 B	T	6	930	0,37	0,98	55/F	80	-	64

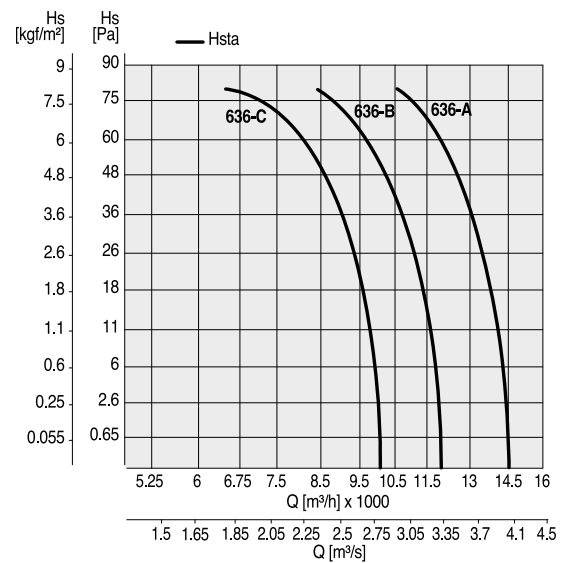
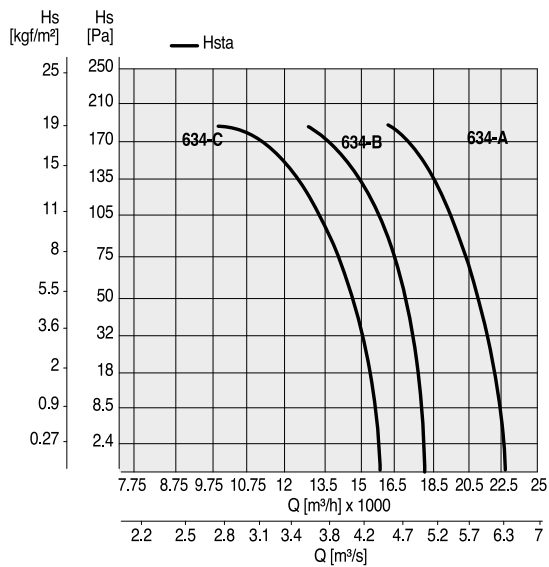

CC SHT 634

Code F300/120	Code F400	Tipo Type	Mod. Model	U P	rpm	Pm (kW)	In (A)	IP/CL	Mot. (Gr)	IE3	Lp dB(A)
1CS3020	1CS4016		634 A	T 4	1420	2,20	4,56	55/F	90	✓	74
1CS3021	1CS4017	CC SHT	634 B	T 4	1440	1,50	3,17	55/F	90	✓	71
1CS3022	1CS4018		634 C	T 4	1415	1,10	2,35	55/F	80	✓	71

CC SHT 636

Code F300/120	Code F400	Tipo Type	Mod. Model	U P	rpm	Pm (kW)	In (A)	IP/CL	Mot. (Gr)	IE3	Lp dB(A)
1CS3023	1CS4019		636 A	T 6	930	0,55	1,48	55/F	80	-	68
1CS3024	1CS4020	CC SHT	636 B	T 6	930	0,37	0,98	55/F	80	-	68
1CS3025	1CS4021		636 C	T 6	930	0,37	0,98	55/F	80	-	68

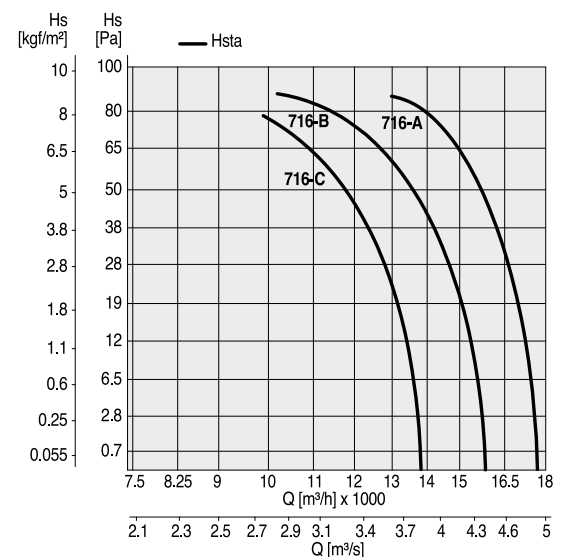
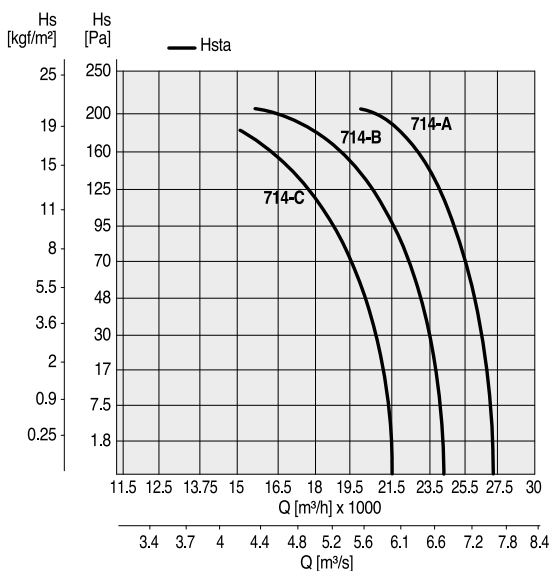

CC SHT 714

Code F300/120	Code F400	Tipo Type	Mod. Model	U P	rpm	Pm (kW)	In (A)	IP/CL	Mot. (Gr)	IE3	Lp dB(A)
1CS3026	1CS4022		714 A	T 4	1410	3,00	6,07	55/F	100	✓	77
1CS3027	1CS4023	CC SHT	714 B	T 4	1420	2,20	4,56	55/F	100	✓	72
1CS3028	1CS4024		714 C	T 4	1420	1,50	3,17	55/F	90	✓	72

CC SHT 716

Code F300/120	Code F400	Tipo Type	Mod. Model	U P	rpm	Pm (kW)	In (A)	IP/CL	Mot. (Gr)	IE3	Lp dB(A)
1CS3029	1CS4025		716 A	T 6	920	0,75	1,93	55/F	90	✓	71
1CS3030	1CS4026	CC SHT	716 B	T 6	930	0,55	1,48	55/F	80	-	71
1CS3031	1CS4027		716 C	T 6	930	0,37	0,98	55/F	80	-	72

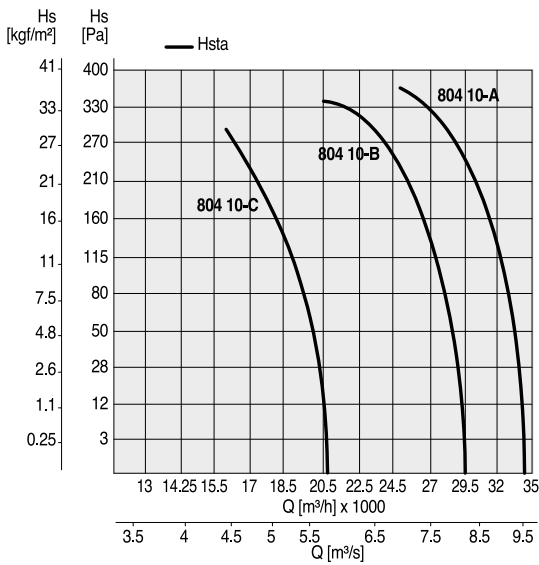

CC SHT 804

Code F300/120	Code F400	Tipo Type	Mod. Model	U	P	rpm	Pm (kW)	In (A)	IP/CL	Mot. (Gr)	IE3	Lp dB(A)
1CS3032	1CS4028		804 A	T	4	1465	5,50	10,4	55/F	132	✓	79
1CS3033	1CS4029	CC SHT	804 B	T	4	1430	4,00	8,23	55/F	112	✓	78
1CS3034	1CS4030		804 C	T	4	1410	3,00	6,07	55/F	100	✓	76

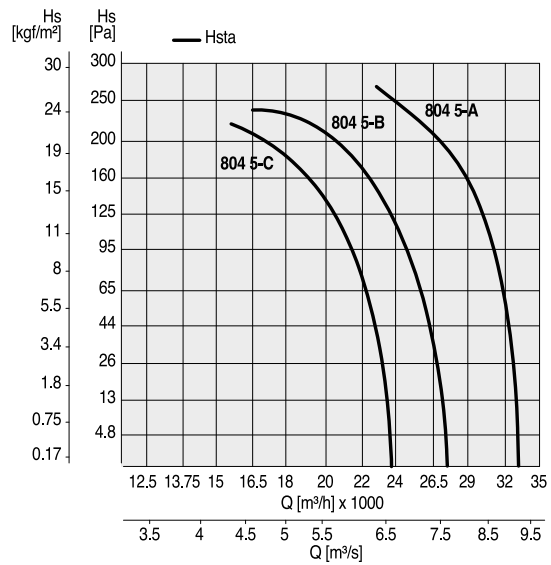

CC SHT 804 5/10

Code F300/120	Code F400	Tipo Type	Mod. Model	U	P	rpm	Pm (kW)	In (A)	IP/CL	Mot. (Gr)	IE3	Lp dB(A)
1CS3038	1CS4034		804 A 5/10	T	4	1430	4,00	8,23	55/F	112	✓	76
1CS3039	1CS4035	CC SHT	804 B 5/10	T	4	1410	3,00	6,07	55/F	100	✓	74
1CS3040	1CS4036		804 C 5/10	T	4	1420	2,20	4,56	55/F	100	✓	76

5/10: 5 pale su mozzo 10 | 5/10 blades

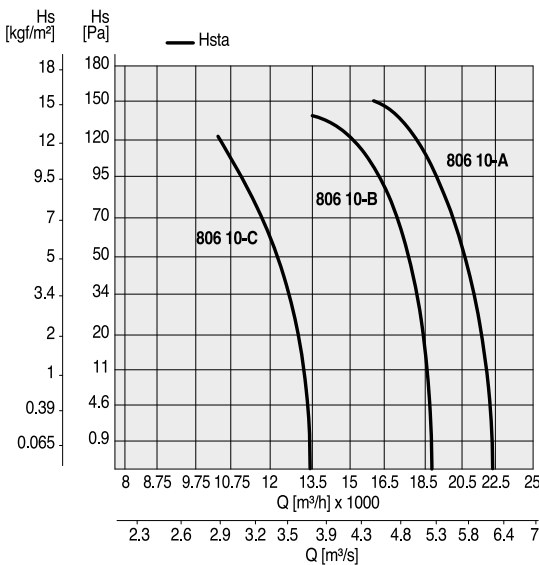

CC SHT 806

Code F300/120	Code F400	Tipo Type	Mod. Model	U	P	rpm	Pm (kW)	In (A)	IP/CL	Mot. (Gr)	IE3	Lp dB(A)
1CS3035	1CS4031		806 A	T	6	940	1,50	3,70	55/F	100	✓	75
1CS3036	1CS4032	CC SHT	806 B	T	6	925	1,10	2,69	55/F	90	✓	75
1CS3037	1CS4033		806 C	T	6	920	0,75	1,93	55/F	90	✓	74

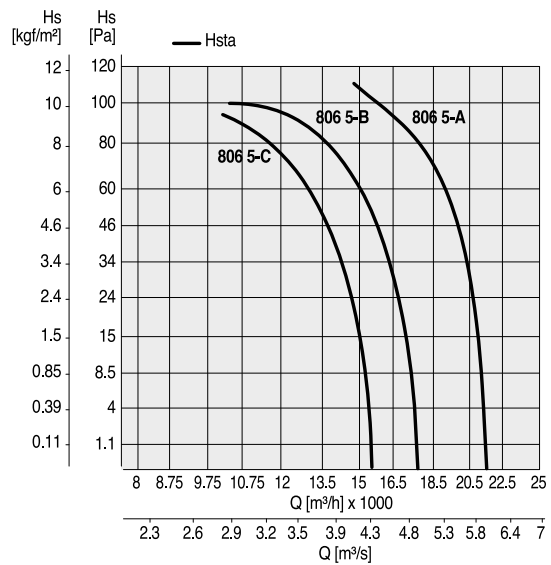

CC SHT 806 5/10

Code F300/120	Code F400	Tipo Type	Mod. Model	U	P	rpm	Pm (kW)	In (A)	IP/CL	Mot. (Gr)	IE3	Lp dB(A)
1CS3041	1CS4037		806 A 5/10	T	6	925	1,10	2,69	55/F	90	✓	69
1CS3042	1CS4038	CC SHT	806 B 5/10	T	6	920	0,75	1,93	55/F	90	✓	69
1CS3043	1CS4039		806 C 5/10	T	6	930	0,75	1,93	55/F	80	✓	69

5/10: 5 pale su mozzo 10 | 5/10 blades

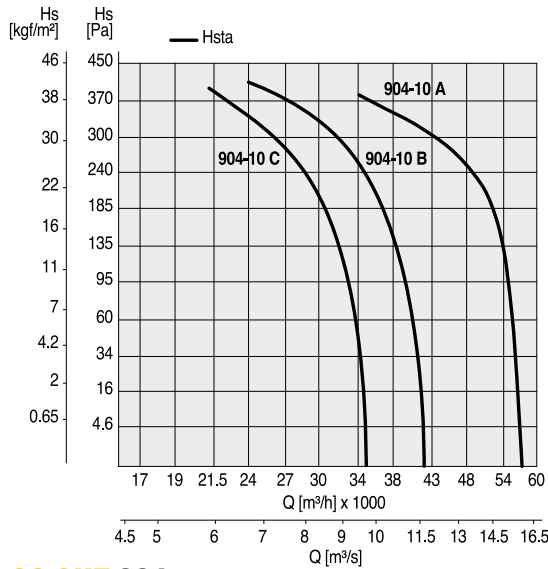

CC SHT 904

Code F300/120	Code F400	Tipo Type	Mod. Model	U	P	rpm	Pm (kW)	In (A)	IP/CL	Mot. (Gr)	IE3	Lp dB(A)
1CS3044	1CS4040		904 A	T	4	1465	11,00	20,9	55/F	160	✓	82
1CS3045	1CS4041	CC SHT	904 B	T	4	1465	7,50	14,2	55/F	132	✓	80
1CS3046	1CS4042		904 C	T	4	1430	5,50	10,4	55/F	132	✓	78

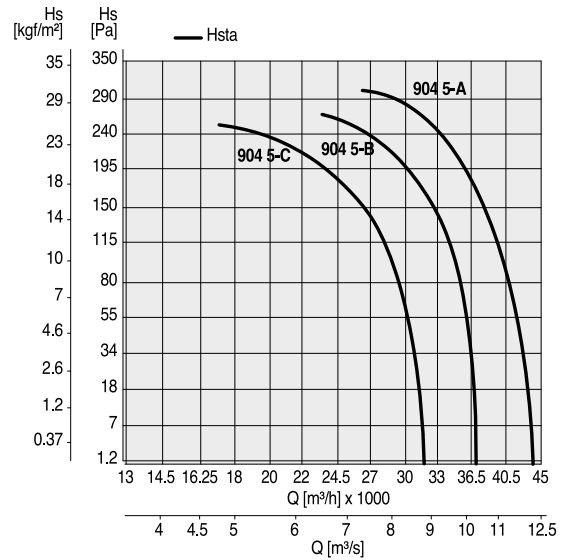

CC SHT 904 5/10

Code F300/120	Code F400	Tipo Type	Mod. Model	U	P	rpm	Pm (kW)	In (A)	IP/CL	Mot. (Gr)	IE3	Lp dB(A)
1CS3050	1CS4046		904 A 5/10	T	4	1465	5,50	10,4	55/F	132	✓	76
1CS3051	1CS4047	CC SHT	904 B 5/10	T	4	1430	4,00	8,23	55/F	112	✓	75
1CS3052	1CS4048		904 C 5/10	T	4	1410	3,00	6,07	55/F	100	✓	74

5/10: 5 pale su mozzo 10 | 5/10 blades

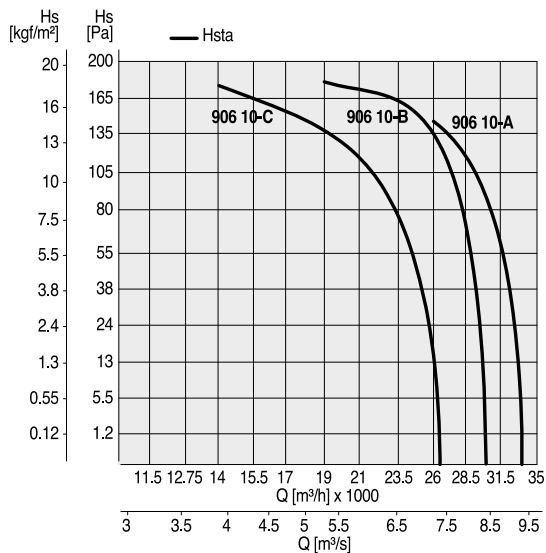

CC SHT 906

Code F300/120	Code F400	Tipo Type	Mod. Model	U	P	rpm	Pm (kW)	In (A)	IP/CL	Mot. (Gr)	IE3	Lp dB(A)
1CS3047	1CS4043		906 A	T	6	960	3,00	6,91	55/F	132	✓	74
1CS3048	1CS4044	CC SHT	906 B	T	6	940	2,20	5,22	55/F	112	✓	73
1CS3050	1CS4045		906 C	T	6	940	1,50	3,70	55/F	100	✓	71

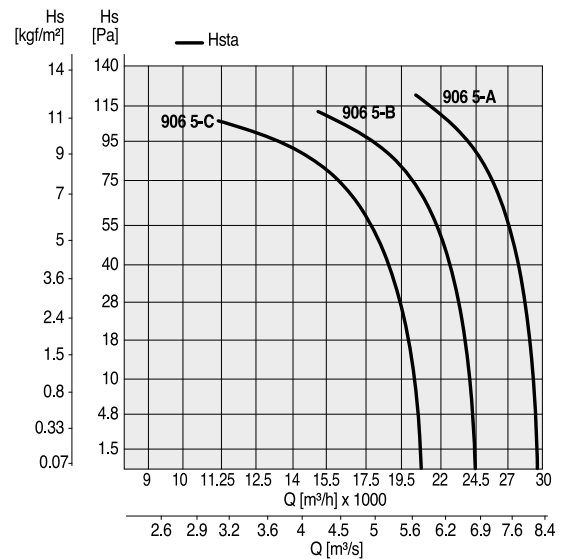

CC SHT 906 5/10

Code F300/120	Code F400	Tipo Type	Mod. Model	U	P	rpm	Pm (kW)	In (A)	IP/CL	Mot. (Gr)	IE3	Lp dB(A)
1CS3053	1CS4049		906 A 5/10	T	6	940	1,50	3,70	55/F	100	✓	71
1CS3054	1CS4050	CC SHT	906 B 5/10	T	6	925	1,10	2,69	55/F	90	✓	69
1CS3055	1CS4051		906 C 5/10	T	6	920	0,75	1,93	55/F	90	✓	69

5/10: 5 pale su mozzo 10 | 5/10 blades

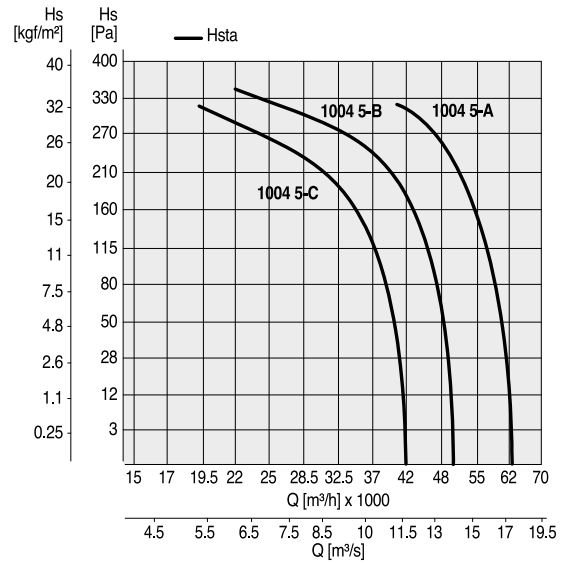
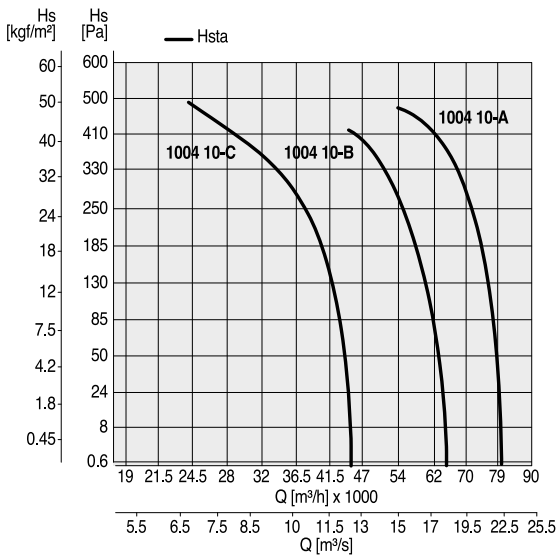

CC SHT 1004

Code F300/120	Code F400	Tipo Type	Mod. Model	U	P	rpm	Pm (kW)	In (A)	IP/CL	Mot. (Gr)	IE3	Lp dB(A)
1CS3056	1CS4052		1004 A	T	4	1455	15,00	27,9	55/F	160	✓	88
1CS3057	1CS4053	CC SHT	1004 B	T	4	1455	11,00	21,0	55/F	160	✓	85
1CS3058	1CS4054		1004 C	T	4	1455	7,50	14,2	55/F	132	✓	83

CC SHT 1004 5/10

Code F300/120	Code F400	Tipo Type	Mod. Model	U	P	rpm	Pm (kW)	In (A)	IP/CL	Mot. (Gr)	IE3	Lp dB(A)
1CS3062	1CS4058		1004 A 5/10	T	4	1465	7,50	14,2	55/F	132	✓	86
1CS3063	1CS4059	CC SHT	1004 B 5/10	T	4	1465	5,50	10,4	55/F	132	✓	86
1CS3064	1CS4060		1004 C 5/10	T	4	1465	4,00	8,23	55/F	112	✓	85

5/10: 5 pale su mozzo 10 | 5/10 blades

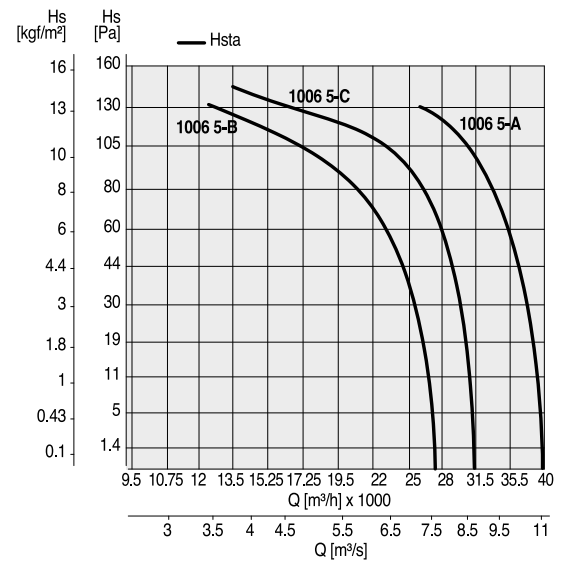
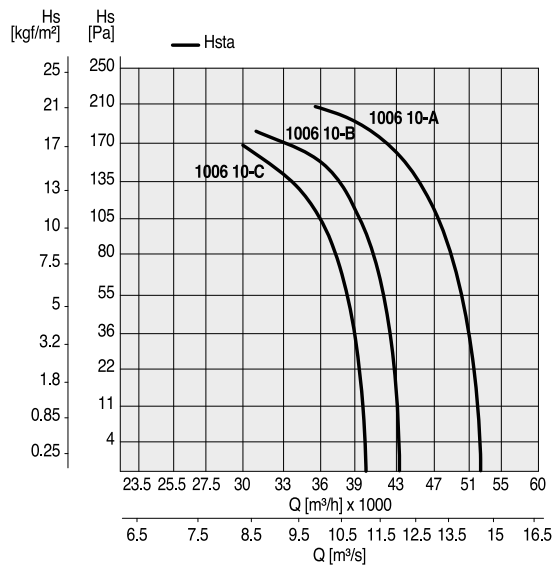

CC SHT 1006

Code F300/120	Code F400	Tipo Type	Mod. Model	U	P	rpm	Pm (kW)	In (A)	IP/CL	Mot. (Gr)	IE3	Lp dB(A)
1CS3059	1CS4055		1006 A	T	6	960	5,50	12,9	55/F	132	✓	86
1CS3060	1CS4056	CC SHT	1006 B	T	6	960	4,00	9,11	55/F	132	✓	84
1CS3061	1CS4057		1006 C	T	6	960	3,00	6,91	55/F	132	✓	82

CC SHT 1006 5/10

Code F300/120	Code F400	Tipo Type	Mod. Model	U	P	rpm	Pm (kW)	In (A)	IP/CL	Mot. (Gr)	IE3	Lp dB(A)
1CS3065	1CS4061		1006 A 5/10	T	6	940	2,20	5,22	55/F	112	✓	81
1CS3066	1CS4062	CC SHT	1006 B 5/10	T	6	940	1,50	3,70	55/F	100	✓	81
1CS3067	1CS4063		1006 C 5/10	T	6	925	1,10	2,69	55/F	90	✓	81

5/10: 5 pale su mozzo 10 | 5/10 blades



F400

Gli accessori qui elencati sono costruiti in conformità alla **Norma EN12101-3** e certificati per uso ad alta temperatura in **classe F400** (400°C per 2 ore).

The accessories here listed are designed according to **EN12101-3** and are certified for high temperature use, **Class F400** (400°C for 2 hours).

CC SHT

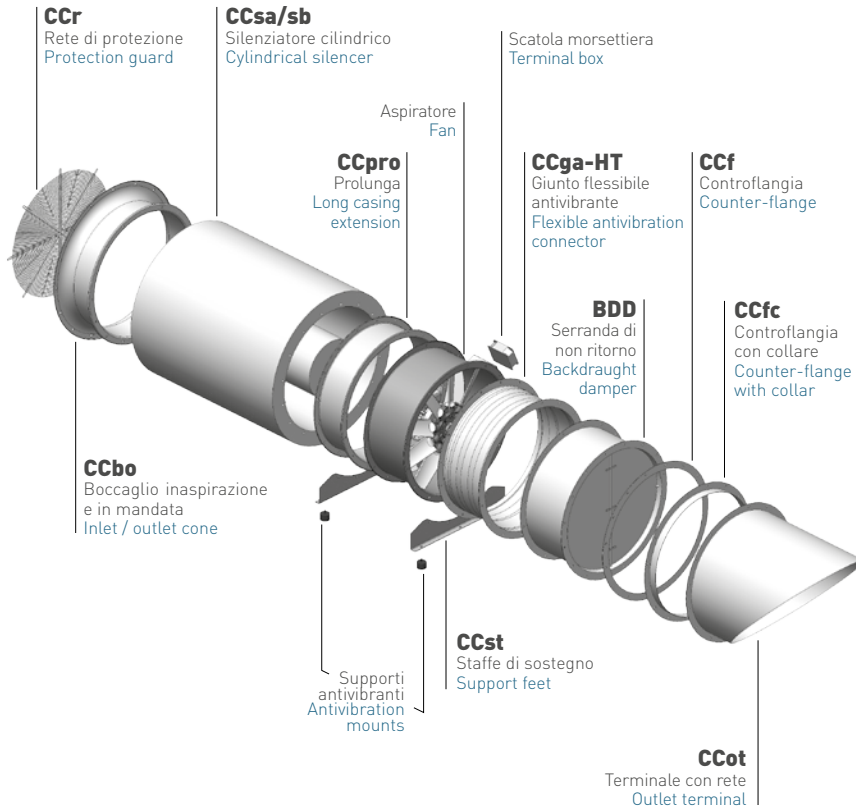

TA HT

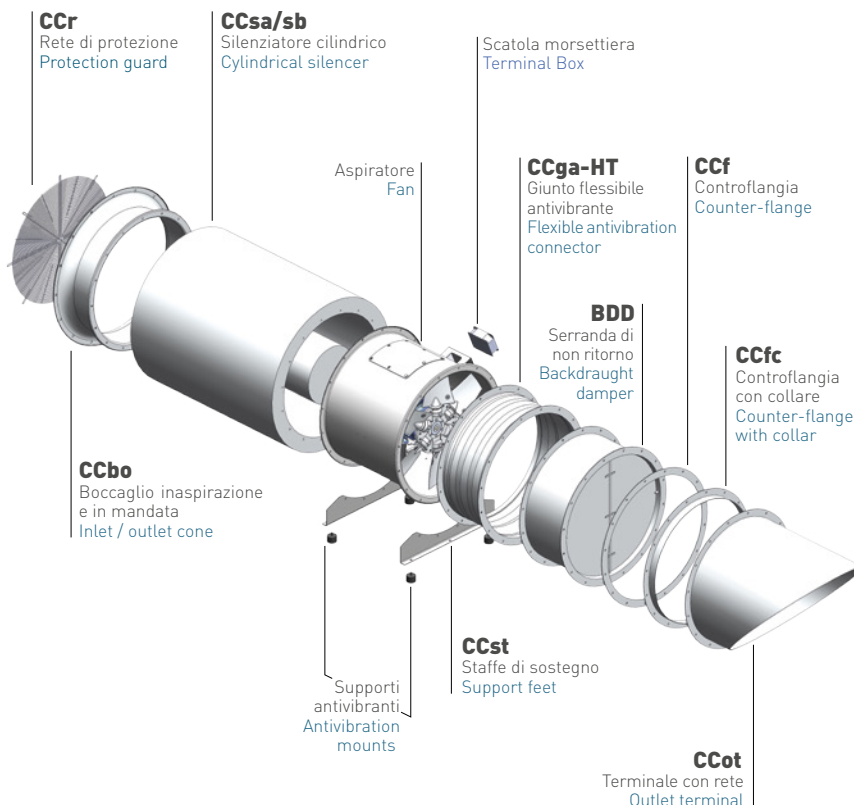

sez.
1.2

accessori | accessories



CCr | RETI PROTEZIONE | PROTECTION GUARDS F400

Salvaguardano dal contatto accidentale con le parti in movimento del ventilatore. Realizzate in filo d'acciaio e protette contro gli agenti atmosferici. CCr: versione piana (per cassa lunga e cassa corta lato girante),

They prevent from casual contact with moving parts of the fan. Manufactured in steel rod and protected against atmospheric agents. CCr: flat version (for long case and short case on impeller side)

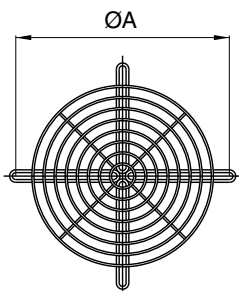

Code	Tipo Type	ØA	Kg
5RE9032	CCr 31	355	0,4
5RE9036	CCr 35	395	0,6
5RE9041	CCr 40	450	0,7
5RE9046	CCr 45	500	1,0
5RE9051	CCr 50	560	1,4
5RE9057	CCr 56	620	2,0
5RE9064	CCr 63	690	2,2
5RE9072	CCr 71	770	2,7
5RE9083	CCr 80	860	4,0
5RE9093	CCr 90	970	5,0
5RE9101	CCr 100	1070	5,0
5RE9102	CCr 112	1190	6,0
5RE9105	CCr 125	1320	9,0
5RE9110	CCr 140	1490	12
5RE9113	CCr 160	1690	14

Dimensioni in mm | Dimensions in mm

CCrc | RETE CONICA | CONE GRID F400

Salvaguardano dal contatto accidentale con le parti in movimento del ventilatore.

Realizzate in filo d'acciaio e protette contro gli agenti atmosferici. CCrc: versione conica (cassa corta lato motore).

They prevent from casual contact with moving parts of the fan. Manufactured in steel rod and protected against atmospheric agents. CCrc: conic version (short case version on motor side).

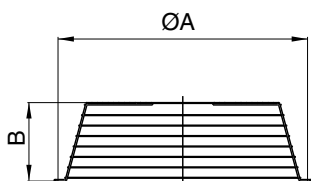

Code	Tipo Type	ØA	B	Kg
5RE1581	CCrc 31	355	115	1
5RE1582	CCrc 35	395	115	1,1
5RE1583	CCrc 40	450	115	1,3
5RE1584	CCrc 45	500	115	1,5
5RE1585	CCrc 50	560	115	1,8
5RE1586	CCrc 56	620	115	2,2
5RE1587	CCrc 63	690	115	3
5RE1588	CCrc 71	770	150	4,5
5RE1589	CCrc 80	860	150	5,8
5RE1590	CCrc 90	970	305	7
5RE1591	CCrc 100	1070	305	8,5
5RE1592	CCrc 112	1190	305	10
5RE1593	CCrc 125	1320	305	11

Dimensioni in mm - 1400/1600 a richiesta
Dimensions in mm - 1400/1600 upon request

CCbo | BOCCAGLIO | INLET/OUTLET CONE F400

Permette la realizzazione, anche in sito, della versione a cassa lunga con girante e motore completamente protetti dalla cassa del ventilatore. Costruita in lamiera d'acciaio, con flange di fissaggio realizzate a norma UNI ISO 6580 - EUROVENT. Verniciata a polveri epossipoliestiriche. Completa di portellina d'ispezione e fori per passaggio cavi.

Turns the standard short case execution into a long case version, also at site, with impeller and motor completely protected inside the casing. Manufactured in steel sheet, with fixing flanges according to UNI ISO6580 - EUROVENT standard. Protected against atmospheric agents by epoxy-paint. Complete of inspection porthole and holes for cable entry.

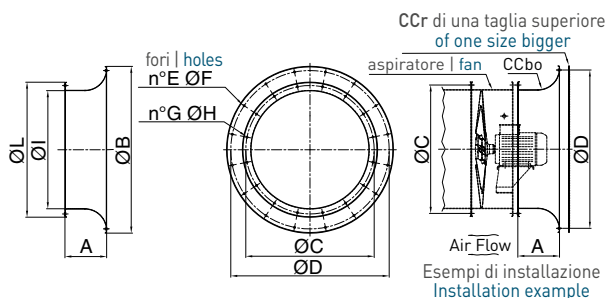

Code	Tipo Type	A	ØB	ØC	ØD	E	ØF	G	ØH	ØI	ØL	Kg
5B09631	CCbo 31	175	442	355	395	8	10	8	10	307	395	4,5
5B09635	CCbo 35	175	496	395	450	8	12	8	10	357	446	5
5B09640	CCbo 40	175	546	450	500	8	12	8	12	407	496	5,6
5B09645	CCbo 45	175	598	500	560	12	12	8	12	457	546	6,3
5B09650	CCbo 50	190	658	560	620	12	12	12	12	507	598	8,5
5B09656	CCbo 56	190	730	620	690	12	12	12	12	567	730	8,5
5B09663	CCbo 63	190	810	690	770	16	12	12	12	637	810	9,8
5B09671	CCbo 71	230	910	770	860	16	12	16	12	708	910	12,4
5B09680	CCbo 80	250	1025	860	970	16	16	16	12	808	1025	15,2
5B09690	CCbo 90	300	1125	970	1070	16	16	16	16	910	1125	29,4
5B09700	CCbo 100	300	1245	1070	1190	20	16	16	16	1010	1245	33,3
5B09712	CCbo 112	300	1380	1190	1320	20	16	20	16	1130	1380	37,3
5B09725	CCbo 125	300	1525	1320	1470	20	16	20	16	1260	1525	42,5

Dimensioni in mm - 1400/1600 a richiesta
Dimensions in mm - 1400/1600 upon request

N.B.: Il flusso dell'aria potrebbe cambiare da girante a motore.
Airflow direction could vary from impeller to motor.



CCsa | CCsb | SILENZIATORI CILINDRICI | CYLINDRICAL SILENCERS

I silenziatori cilindrici CCs sono disponibili in due versioni, senza ogiva (CCsa) e con ogiva (CCsb). La presenza dell'ogiva permette una maggiore attenuazione della rumorosità ma genera una perdita di carico aggiuntiva nell'impianto. Entrambe le versioni possono essere fissate alla flangia del CC corrispondente sia in aspirazione sia in mandata. La serie CCsa, non genera perdite di carico aggiuntive. La serie CCsb, comporta una perdita di carico nella misura evidenziata nel diagramma di pagina **. E' possibile fornire i silenziatori in versione di lunghezza pari a 1 - 1,5 - 2 volte il diametro (b). Questi silenziatori sono costruiti completamente in lamiera zincata, la parte interna e l'ogiva in lamiera forata al fine di permettere, efficacemente, l'azione del materassino fonoassorbente in lana minerale. La temperatura d'esercizio è compresa fra -40 e +150°C in servizio S1. Sono certificati nelle stesse categorie di temperatura dei CC HT / CC SHT in servizio d'emergenza.

The cylindrical silencers CCs are available in two versions, without pod (CCsa) and with pod (CCsb). The presence of the pod allows a higher noise attenuation, but creates an additional pressure drop in the system. Both the versions can be fixed to the corresponding flange of the CC in inlet and outlet. The CCsa series doesn't create additional losses. The CCsb series gives an additional loss, as shown in the diagram at page **. Silencers can be provided with length equal to 1 - 1,5 - 2 times the diameter (b). These silencers are manufactured completely in galvanized steel. The internal part and the pod are made in perforated sheet, to effectively allow the sound absorption of the acoustic lining in mineral wool. The working temperature is included from -40°C and +150°C in S1 service. They are certified in the same categories of temperature as CC HT / CC SHT in emergency service.

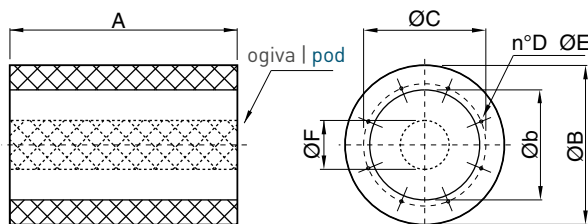

CCsa | CCsb

Tipo Type	ØB	Øb	ØC	D	ØE	ØF
40	540	400	450	8	M10	195
45	610	450	500	8	M10	195
50	660	500	560	12	M10	250
56	720	560	620	12	M10	250
63	790	630	690	12	M10	300
71	870	710	770	16	M10	380
80	1000	800	860	16	M10	380
90	1100	900	970	16	M12	380
100	1200	1000	1070	16	M12	655
112	1320	1120	1190	20	M12	655
125	1450	1250	1320	20	M12	655

CCsa

Tipo Type	A 1Ø	Kg	A 1,5Ø	Kg	A 2Ø	Kg
40	400	12	600	17	800	21
45	450	15	675	20	900	24
50	500	18	750	25	1000	32
56	560	21	840	28	1120	35
63	630	24	945	33	1260	43
71	710	35	1065	49	1420	63
80	800	43	1200	61	1600	79
90	900	70	1350	94	1800	112
100	1000	113	1500	137	2000	161
112	1120	130	1680	154	2240	178
125	1250	152	1875	185	2500	213

CCsb

Tipo Type	A 1Ø	Kg	A 1,5Ø	Kg	A 2Ø	Kg
40	400	14	600	21	800	26
45	450	17	675	24	900	29
50	500	23	750	32	1000	39
56	560	28	840	37	1120	44
63	630	32	945	44	1260	55
71	710	44	1065	62	1420	78
80	800	56	1200	79	1600	101
90	900	130	1350	153	1800	175
100	1000	143	1500	180	2000	216
112	1120	165	1680	202	2240	238
125	1250	193	1875	240	2500	282

Dimensioni in mm | Dimensions in mm

CCpro | PROLUNGA | LONG CASING EXTENSION (solo per | only for CC SHT) F400

Permette la realizzazione, anche in sito, della versione a cassa lunga con girante e motore completamente protetti dalla cassa del ventilatore. Costruita in lamiera d'acciaio, con flange di fissaggio realizzate a norma UNI ISO 6580 - EUROVENT. Verniciata a polveri epossipoliestiriche. Completa di portellina d'ispezione e fori per passaggio cavi.

Turns the standard short case execution into a long case version, also at site, with impeller and motor completely protected inside the casing. Manufactured in steel sheet, with fixing flanges according to UNI ISO6580 - EUROVENT standard. Protected against atmospheric agents by epoxy-paint. Complete of inspection porthole and holes for cable.

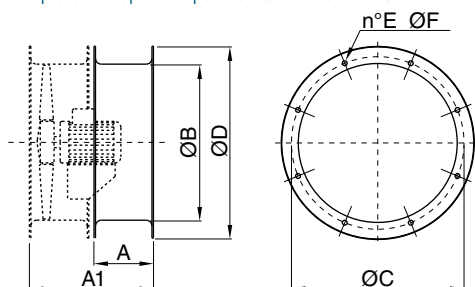

Code	Tipo Type	A	A1	ØB	ØC	ØD	E	ØF	Kg
1CC9313	CCpro 31	180	380	305	355	395	8	10	4
1CC9351	CCpro 35	180	380	355	395	446	8	10	5
1CC9402	CCpro 40	200	430	400	450	496	8	12	6
1CC9451	CCpro 45	200	430	450	500	546	8	12	7
1CC9502	CCpro 50	200	450	500	560	598	12	12	8
1CC9561	CCpro 56	200	450	560	620	658	12	12	9
1CC9632	CCpro 63	240	490	630	690	730	12	12	11
1CC9712	CCpro 71	280	530	710	770	810	16	12	13
1CC9802	CCpro 80	240	590	800	860	910	16	12	20
1CC9901	CCpro 90	340	690	900	970	1030	16	16	31
1CC9912	CCpro 100	410	760	1000	1070	1130	16	16	39
1CC9921	CCpro 112	410	760	1120	1190	1250	20	16	58
1CC9927	CCpro 125	410	760	1250	1320	1380	20	16	65
1CC9930	CCpro 140	510	960	1415	1470	1540	20	16	88
1CC9931	CCpro 160	510	960	1615	1680	1730	24	18	98

Dimensioni in mm | Dimensions in mm



CCst | STAFFE DI SOSTEGNO | SUPPORT FEET F400

Consentono l'ancoraggio del ventilatore a pavimento o soffitto. Realizzate in lamiera d'acciaio e verniciate a polveri epossipoliestiriche.

Suitable to fasten the fan on the floor or to the ceiling. Manufactured in steel sheet and protected against atmospheric agents by epoxy paint.

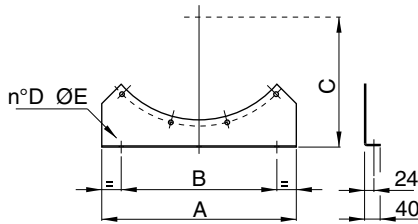

Code*	Tipo Type	A	B	C	D	ØE	Kg**
1ST0310	CCst 31	320	200	280	2	10	1,1
1ST0350	CCst 35	350	250	300	2	10	1,25
1ST0400	CCst 40	400	300	320	2	10	1,3
1ST0450	CCst 45	450	350	350	2	10	1,5
1ST0500	CCst 50	500	400	380	2	10	2,1
1ST0560	CCst 56	560	460	410	2	10	2,5
1ST0630	CCst 63	630	480	450	2	10	2,8
1ST0710	CCst 71	710	550	490	2	10	3,1
1ST0800	CCst 80	800	660	540	3	14	3,7
1ST0900	CCst 90	900	760	600	3	14	4,5
1ST1000	CCst 100	1000	860	640	3	14	4,8
1ST1120	CCst 112	1120	980	710	3	14	6,8
1ST1250	CCst 125	1250	950	770	3	14	7,8
1ST1400	CCst 140	1400	1100	850	3	14	11
1ST1600	CCst 160	1600	1300	960	3	16	21,5

Dimensioni in mm - * Codice della coppia - ** Peso di una staffa
Dimensions in mm - Item code of the set of 2 - Weight of a single support

CCga-HT | GIUNTO ANTIVIBRANTE | FLEXIBLE CONNECTORS F400

Impedisce la propagazione delle vibrazioni sulla canalizzazione. Costruito con due flange in lamiera d'acciaio, realizzate a norma UNI ISO 6580 - EUROVENT per il fissaggio al ventilatore e al canale, ed un nastro di collegamento flessibile e robusto. Adatto all'utilizzo ad alte temperature. Parti in lamiera verniciate a polveri epossipoliestiriche.

It prevents the propagation of vibrations along the ducted system. Manufactured with two flanges in steel sheet, according to UNI ISO 6580 - EUROVENT standard for fixing to the fan and to the duct, and a strong flexible fabric joint. Suitable for high temperature working. Components in steel sheet protected against atmospheric agents by epoxy paint.

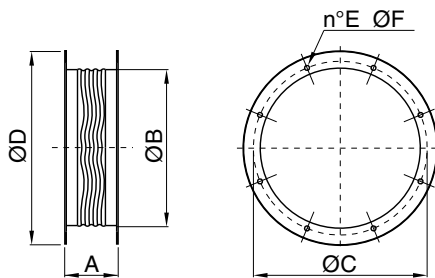

Code	Tipo Type	A	ØB	ØC	ØD	E	ØF	Kg
1SU5313	CCga 31	200	305	355	395	8	10	3,7
1SU5351	CCga 35	200	355	395	446	8	10	4,2
1SU5401	CCga 40	200	400	450	496	8	12	4,6
1SU5451	CCga 45	200	450	500	546	8	12	5,2
1SU5501	CCga 50	200	500	560	598	12	12	5,7
1SU5562	CCga 56	200	560	620	658	12	12	6,8
1SU5632	CCga 63	200	630	690	730	12	12	7,6
1SU5711	CCga 71	200	710	770	810	16	12	8,4
1SU5802	CCga 80	200	800	860	910	16	12	9,5
1SU5901	CCga 90	200	900	970	1030	16	16	10,8
1SU6001	CCga 100	200	1000	1070	1130	16	16	12,5
1SU5910	CCga 112	200	1120	1190	1250	20	16	14,1
1SU5911	CCga 125	200	1250	1320	1380	20	16	15,8
1SU6140	CCga 140	200	1415	1470	1540	20	16	38
1SU6160	CCga 160	200	1615	1680	1730	24	18	44

Dimensioni in mm | Dimensions in mm



BDD | SERRANDA DI CHIUSURA | BACKDRAUGHT DAMPER F400

Serrande di chiusura che consentono il ritorno delle alette in posizione tappata. Evitano inutili dispersioni di calore e richiedono un'irrelevante perdita di carico. Le alette della serranda si aprono con la depressione dell'aria generata dal ventilatore in moto. Si chiudono per gravità al suo spegnimento nelle versioni "V" (Flusso dell'aria verticale) e con l'aiuto di molle nelle versioni "H" (Flusso dell'aria orizzontale). Cassa è realizzata in lamiera verniciata e alette in lamiera zincata.

Backdraught damper that allow the return of the flaps in closed position. They avoid heat dispersion when the fan is off and require a negligible opening pressure. The shutter flaps are opened by the air depression produced by the fan when working. They shut down by gravity when the fan is switched off in the "V" versions (Vertical flow discharge) and thanks to springs in the "H" versions (Horizontal flow discharge).

Casing in painted steel sheet and flaps in galvanized steel sheet.

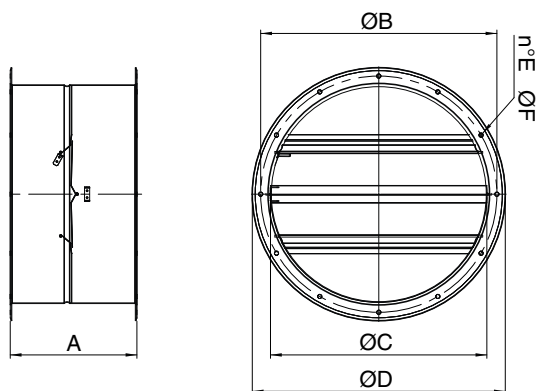

Code	Flusso* Flow	Tipo Type	ØA	ØB	ØC	ØD	E	ØF
1SE9247	H	BDD 400	350	450	405	500	8	12
1SE9262	V							
1SE9248	H	BDD 450	420	500	455	560	8	12
1SE9263	V							
1SE9249	H	BDD 500	370	560	505	610	12	12
1SE9264	V							
1SE9250	H	BDD 560	370	620	565	670	12	12
1SE9265	V							
1SE9251	H	BDD 630	370	690	635	740	12	12
1SE9266	V							
1SE9252	H	BDD 710	430	770	708	812	16	12
1SE9267	V							
1SE9253	H	BDD 800	450	860	808	912	16	12
1SE9268	V							
1SE9254	H	BDD 900	450	970	908	1012	16	16
1SE9269	V							
1SE9255	H	BDD 1000	400	1070	1010	1122	16	16
1SE9270	V							
1SE9256	H	BDD 1120	470	1190	1130	1242	20	16
1SE9271	V							
1SE9257	H	BDD 1250	470	1320	1260	1372	20	16
1SE9272	V							
1SE9258	H	BDD 1400	470	1460	1410	1522	20	16
1SE9273	V							

* H = Flusso dell'aria orizzontale del ventilatore - Horizontal flow discharge of the fan
V = Flusso dell'aria verticale del ventilatore - Vertical flow discharge of the fan

CCf | CONTROFLANGIA | COUNTER FLANGE F400

Piastra a forma di anello provvista di fori a norma UNI ISO 6580 - EUROVENT. Viene utilizzata per facilitare il collegamento tra il canale ed il ventilatore.

Ring plate with holes according to UNI ISO6580 - EUROVENT standard, compatible with fan flange. It is used for easier connection between the CC fan and the duct.

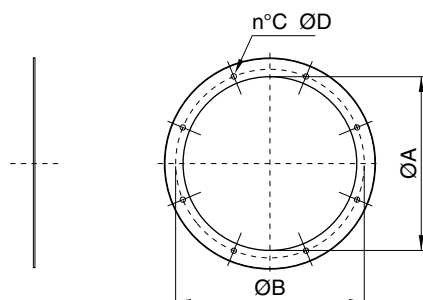

Code	Tipo Type	ØA	ØB	C	ØD	Kg
5B01031	CCf 31	315	355	8	10	1,2
5B01035	CCf 35	350	395	8	10	1,5
5B01040	CCf 40	400	450	8	12	1,7
5B01045	CCf 45	450	500	8	12	1,9
5B01050	CCf 50	500	560	12	12	2,1
5B01056	CCf 56	560	620	12	12	2,4
5B01063	CCf 63	630	690	12	12	2,7
5B01071	CCf 71	710	770	16	12	3,3
5B01081	CCf 80	800	860	16	12	3,7
5B01092	CCf 90	900	970	16	16	4,7
5B01110	CCf 100	1000	1070	16	16	5,2
5B01212	CCf 112	1120	1190	20	16	6,5
5B01210	CCf 125	1250	1320	20	16	8
-	CCf 140	1415	1470	20	16	10
-	CCf 160	1615	1680	24	18	12

Dimensioni in mm - 1400/1600: codice a richiesta
Dimensions in mm - item codes upon request



CCfc | CONTROFLANGIA CON COLLARE | COUNTER FLANGE WITH COLLAR F400

Controflangia a forma di anello con collare, provvista di fori a norma UNI ISO 6580 - EUROVENT. Viene utilizzata per facilitare il collegamento tra il canale ed il ventilatore.

Counter flange with addition of 80 mm of round duct. It is used for easier connection between the CC fan and the duct.

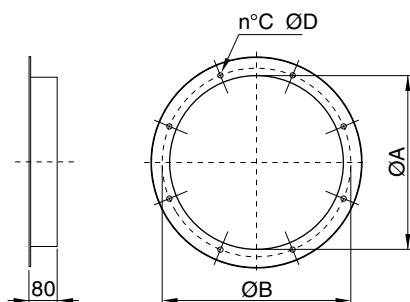

Code	Tipo Type	ØA	ØB	C	ØD	Kg
5B01531	CCfc 31	305	355	8	10	1,3
5B01535	CCfc 35	355	395	8	10	1,5
5B01540	CCfc 40	405	450	8	12	1,7
5B01545	CCfc 45	455	500	8	12	2
5B01550	CCfc 50	505	560	12	12	2,2
5B01556	CCfc 56	565	620	12	12	2,5
5B01563	CCfc 63	635	690	12	12	2,9
5B01571	CCfc 71	708	770	16	12	3,3
5B01580	CCfc 80	808	860	16	12	3,8
5B01590	CCfc 90	908	970	16	16	4,2
5B01600	CCfc 100	1010	1070	16	16	5
5B01620	CCfc 112	1130	1190	20	16	5,8
5B01625	CCfc 125	1260	1320	20	16	6,5
-	CCfc 140	1415	1470	20	16	10
-	CCfc 160	1615	1680	24	18	12

Dimensioni in mm | Dimensions in mm

CCot | TERMINALE CON RETE | OUTLET TERMINAL F400

Terminale parapigioggia con rete di protezione.
Outlet terminal with protection guard.

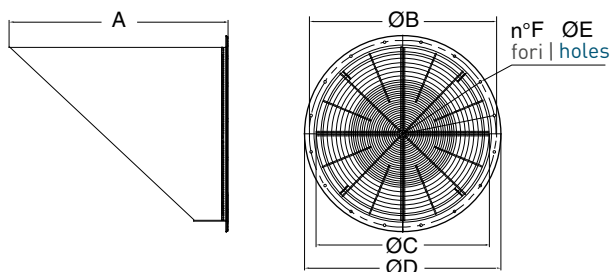

Code	Tipo Type	ØA	ØB	ØC	ØD	ØE	F	Kg
5TR0500	CCot 400	550	450	400	503	8	12	10
5TR0501	CCot 450	600	500	450	553	8	12	11
5TR0502	CCot 500	655	560	500	603	12	12	12,5
5TR0503	CCot 560	710	620	560	663	12	12	15
5TR0504	CCot 630	785	690	630	733	12	12	18
5TR0505	CCot 710	865	770	710	813	16	12	22
5TR0506	CCot 800	950	860	800	903	16	12	39
5TR0507	CCot 900	1050	970	900	1013	16	16	48
5TR0508	CCot 1000	1200	1070	1000	1113	16	16	80
5TR0509	CCot 1120	1325	1190	1120	1233	20	16	97
5TR0510	CCot 1250	1455	1320	1250	1367	20	16	118

Dimensioni in mm | Dimensions in mm

Kit TAV HT | CONVOGLIATORE VERTICALE | CONVEYOR FOR VERTICAL DISCHARGE F400

Convogliatore esterno per espulsione verticale costituito da una base in lamiera verniciata con vernici a polveri epossipoliestiriche e pannelli verticali in lamiera zincata.

Comprende:

- Serranda automatica con alette in alluminio a doppio battente, rivestite di materiale fonoassorbente.
- Piastra di appoggio in lamiera verniciata con vernici a polveri epossipoliestiriche.
- Rete di protezione sulla mandata realizzata DIN 31001 e protetta contro gli agenti atmosferici.

Outer conveyor for vertical exhaust with epoxy painted steel sheet base and with vertical panels in galvanized steel sheet.

The kit includes:

- Double wing aluminium gravity shutters, acoustically lined.
- Support plate in epoxy painted steel sheet.
- Weatherproof outlet protection guard according to norm DIN 31001 and protected against atmospheric agents.

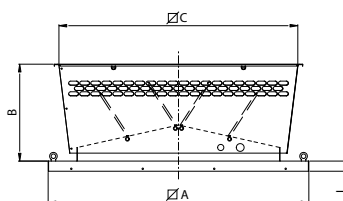

Code	Tipo Type	A	B	C	I	Kg
0807	TAV-HT 800	1285	750	1320	50	95
0907	TAV-HT 900	1285	750	1320	50	95
1007	TAV-HT 1000	1585	600	1530	60	125
1127	TAV-HT 1120	1585	600	1530	60	125
1257	TAV-HT 1250	1843	685	1850	85	160
1407	TAV-HT 1400	1843	685	1850	85	160

Dimensioni in mm | Dimensions in mm



Installabile a tetto per ventilatori assiali intubati
Roof terminal for duct axial fans

sez. 1.2

accessori | accessories



F400

Gli accessori qui elencati sono costruiti in conformità alla **Norma EN12101-3** e certificati per uso ad alta temperatura in **classe F400** (400°C per 2 ore).

The accessories here listed are designed according to **EN12101-3** and are certified for high temperature use, **Class F400** (400°C for 2 hours).

CC SHT

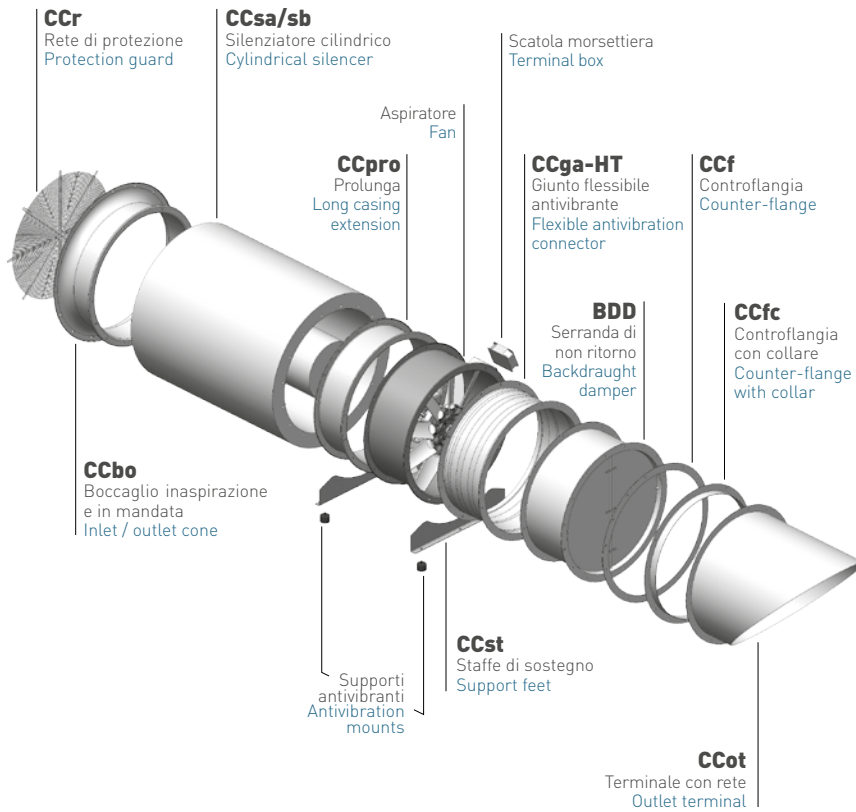

TA HT

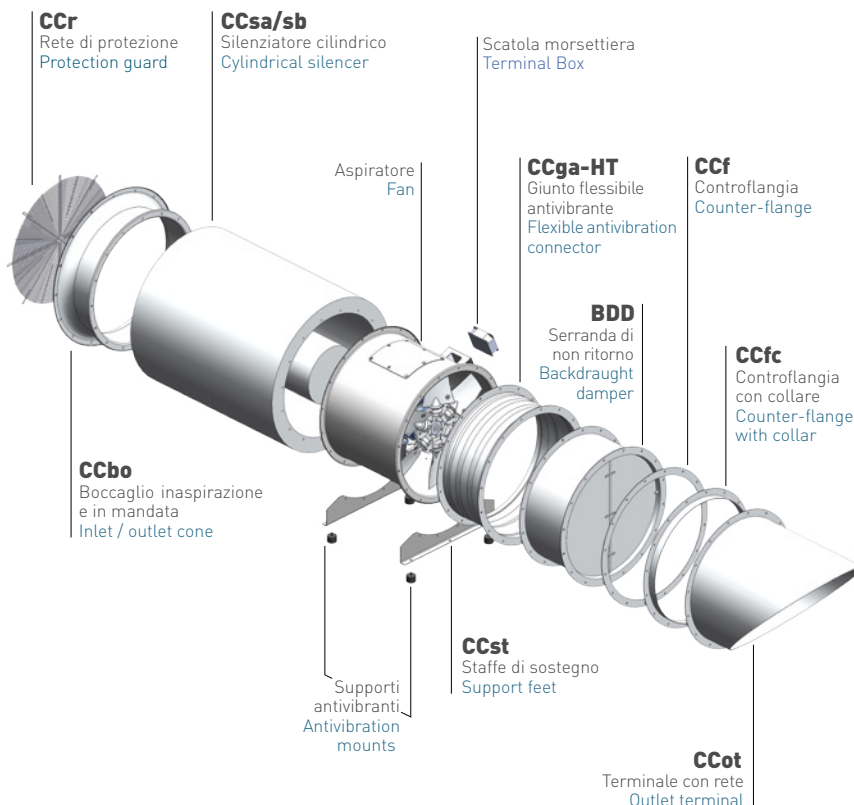

sez.
1.2

accessori | accessories



CCr | RETI PROTEZIONE | PROTECTION GUARDS F400

Salvaguardano dal contatto accidentale con le parti in movimento del ventilatore. Realizzate in filo d'acciaio e protette contro gli agenti atmosferici. CCr: versione piana (per cassa lunga e cassa corta lato girante),

They prevent from casual contact with moving parts of the fan. Manufactured in steel rod and protected against atmospheric agents. CCr: flat version (for long case and short case on impeller side)

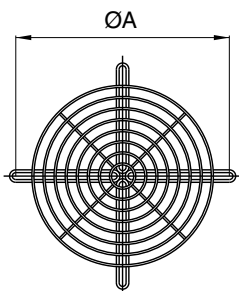

Code	Tipo Type	ØA	Kg
5RE9032	CCr 31	355	0,4
5RE9036	CCr 35	395	0,6
5RE9041	CCr 40	450	0,7
5RE9046	CCr 45	500	1,0
5RE9051	CCr 50	560	1,4
5RE9057	CCr 56	620	2,0
5RE9064	CCr 63	690	2,2
5RE9072	CCr 71	770	2,7
5RE9083	CCr 80	860	4,0
5RE9093	CCr 90	970	5,0
5RE9101	CCr 100	1070	5,0
5RE9102	CCr 112	1190	6,0
5RE9105	CCr 125	1320	9,0
5RE9110	CCr 140	1490	12
5RE9113	CCr 160	1690	14

Dimensioni in mm | Dimensions in mm

CCrc | RETE CONICA | CONE GRID F400

Salvaguardano dal contatto accidentale con le parti in movimento del ventilatore.

Realizzate in filo d'acciaio e protette contro gli agenti atmosferici. CCrc: versione conica (cassa corta lato motore).

They prevent from casual contact with moving parts of the fan. Manufactured in steel rod and protected against atmospheric agents. CCrc: conic version (short case version on motor side).

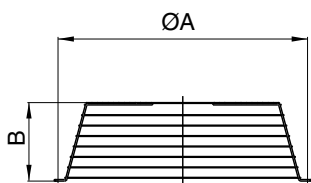

Code	Tipo Type	ØA	B	Kg
5RE1581	CCrc 31	355	115	1
5RE1582	CCrc 35	395	115	1,1
5RE1583	CCrc 40	450	115	1,3
5RE1584	CCrc 45	500	115	1,5
5RE1585	CCrc 50	560	115	1,8
5RE1586	CCrc 56	620	115	2,2
5RE1587	CCrc 63	690	115	3
5RE1588	CCrc 71	770	150	4,5
5RE1589	CCrc 80	860	150	5,8
5RE1590	CCrc 90	970	305	7
5RE1591	CCrc 100	1070	305	8,5
5RE1592	CCrc 112	1190	305	10
5RE1593	CCrc 125	1320	305	11

Dimensioni in mm - 1400/1600 a richiesta
Dimensions in mm - 1400/1600 upon request

CCbo | BOCCAGLIO | INLET/OUTLET CONE F400

Permette la realizzazione, anche in sito, della versione a cassa lunga con girante e motore completamente protetti dalla cassa del ventilatore. Costruita in lamiera d'acciaio, con flange di fissaggio realizzate a norma UNI ISO 6580 - EUROVENT. Verniciata a polveri epossipoliestiriche. Completa di portellina d'ispezione e fori per passaggio cavi.

Turns the standard short case execution into a long case version, also at site, with impeller and motor completely protected inside the casing. Manufactured in steel sheet, with fixing flanges according to UNI ISO6580 - EUROVENT standard. Protected against atmospheric agents by epoxy-paint. Complete of inspection porthole and holes for cable entry.

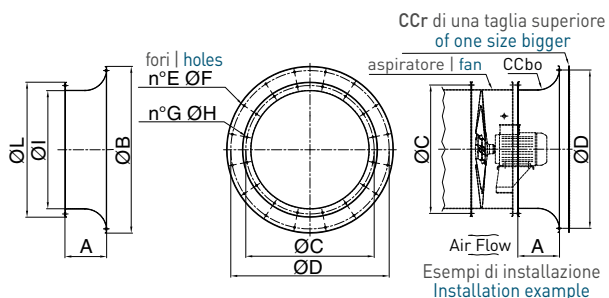

Code	Tipo Type	A	ØB	ØC	ØD	E	ØF	G	ØH	ØI	ØL	Kg
5B09631	CCbo 31	175	442	355	395	8	10	8	10	307	395	4,5
5B09635	CCbo 35	175	496	395	450	8	12	8	10	357	446	5
5B09640	CCbo 40	175	546	450	500	8	12	8	12	407	496	5,6
5B09645	CCbo 45	175	598	500	560	12	12	8	12	457	546	6,3
5B09650	CCbo 50	190	658	560	620	12	12	12	12	507	598	8,5
5B09656	CCbo 56	190	730	620	690	12	12	12	12	567	730	8,5
5B09663	CCbo 63	190	810	690	770	16	12	12	12	637	810	9,8
5B09671	CCbo 71	230	910	770	860	16	12	16	12	708	910	12,4
5B09680	CCbo 80	250	1025	860	970	16	16	16	12	808	1025	15,2
5B09690	CCbo 90	300	1125	970	1070	16	16	16	16	910	1125	29,4
5B09700	CCbo 100	300	1245	1070	1190	20	16	16	16	1010	1245	33,3
5B09712	CCbo 112	300	1380	1190	1320	20	16	20	16	1130	1380	37,3
5B09725	CCbo 125	300	1525	1320	1470	20	16	20	16	1260	1525	42,5

Dimensioni in mm - 1400/1600 a richiesta
Dimensions in mm - 1400/1600 upon request

N.B.: Il flusso dell'aria potrebbe cambiare da girante a motore.
Airflow direction could vary from impeller to motor.



CCsa | CCsb | SILENZIATORI CILINDRICI | CYLINDRICAL SILENCERS

I silenziatori cilindrici CCs sono disponibili in due versioni, senza ogiva (CCsa) e con ogiva (CCsb). La presenza dell'ogiva permette una maggiore attenuazione della rumorosità ma genera una perdita di carico aggiuntiva nell'impianto. Entrambe le versioni possono essere fissate alla flangia del CC corrispondente sia in aspirazione sia in mandata. La serie CCsa, non genera perdite di carico aggiuntive. La serie CCsb, comporta una perdita di carico nella misura evidenziata nel diagramma di pagina **. E' possibile fornire i silenziatori in versione di lunghezza pari a 1 - 1,5 - 2 volte il diametro (b). Questi silenziatori sono costruiti completamente in lamiera zincata, la parte interna e l'ogiva in lamiera forata al fine di permettere, efficacemente, l'azione del materassino fonoassorbente in lana minerale. La temperatura d'esercizio è compresa fra -40 e +150°C in servizio S1. Sono certificati nelle stesse categorie di temperatura dei CC HT / CC SHT in servizio d'emergenza.

The cylindrical silencers CCs are available in two versions, without pod (CCsa) and with pod (CCsb). The presence of the pod allows a higher noise attenuation, but creates an additional pressure drop in the system. Both the versions can be fixed to the corresponding flange of the CC in inlet and outlet. The CCsa series doesn't create additional losses. The CCsb series gives an additional loss, as shown in the diagram at page **. Silencers can be provided with length equal to 1 - 1,5 - 2 times the diameter (b). These silencers are manufactured completely in galvanized steel. The internal part and the pod are made in perforated sheet, to effectively allow the sound absorption of the acoustic lining in mineral wool. The working temperature is included from -40°C and +150°C in S1 service. They are certified in the same categories of temperature as CC HT / CC SHT in emergency service.

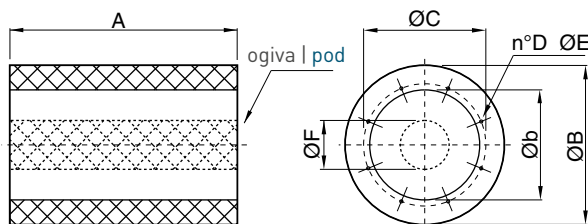

CCsa | CCsb

Tipo Type	ØB	Øb	ØC	D	ØE	ØF
40	540	400	450	8	M10	195
45	610	450	500	8	M10	195
50	660	500	560	12	M10	250
56	720	560	620	12	M10	250
63	790	630	690	12	M10	300
71	870	710	770	16	M10	380
80	1000	800	860	16	M10	380
90	1100	900	970	16	M12	380
100	1200	1000	1070	16	M12	655
112	1320	1120	1190	20	M12	655
125	1450	1250	1320	20	M12	655

CCsa

Tipo Type	A 1Ø	Kg	A 1,5Ø	Kg	A 2Ø	Kg
40	400	12	600	17	800	21
45	450	15	675	20	900	24
50	500	18	750	25	1000	32
56	560	21	840	28	1120	35
63	630	24	945	33	1260	43
71	710	35	1065	49	1420	63
80	800	43	1200	61	1600	79
90	900	70	1350	94	1800	112
100	1000	113	1500	137	2000	161
112	1120	130	1680	154	2240	178
125	1250	152	1875	185	2500	213

CCsb

Tipo Type	A 1Ø	Kg	A 1,5Ø	Kg	A 2Ø	Kg
40	400	14	600	21	800	26
45	450	17	675	24	900	29
50	500	23	750	32	1000	39
56	560	28	840	37	1120	44
63	630	32	945	44	1260	55
71	710	44	1065	62	1420	78
80	800	56	1200	79	1600	101
90	900	130	1350	153	1800	175
100	1000	143	1500	180	2000	216
112	1120	165	1680	202	2240	238
125	1250	193	1875	240	2500	282

Dimensioni in mm | Dimensions in mm

CCpro | PROLUNGA | LONG CASING EXTENSION (solo per | only for CC SHT) F400

Permette la realizzazione, anche in sito, della versione a cassa lunga con girante e motore completamente protetti dalla cassa del ventilatore. Costruita in lamiera d'acciaio, con flange di fissaggio realizzate a norma UNI ISO 6580 - EUROVENT. Verniciata a polveri epossipoliestiriche. Completa di portellina d'ispezione e fori per passaggio cavi.

Turns the standard short case execution into a long case version, also at site, with impeller and motor completely protected inside the casing. Manufactured in steel sheet, with fixing flanges according to UNI ISO6580 - EUROVENT standard. Protected against atmospheric agents by epoxy-paint. Complete of inspection porthole and holes for cable.

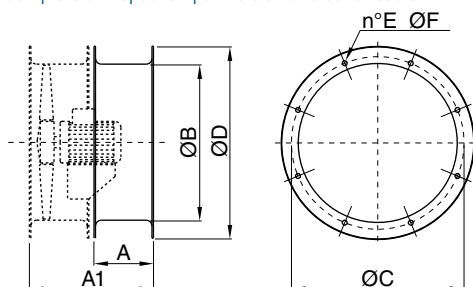

Code	Tipo Type	A	A1	ØB	ØC	ØD	E	ØF	Kg
1CC9313	CCpro 31	180	380	305	355	395	8	10	4
1CC9351	CCpro 35	180	380	355	395	446	8	10	5
1CC9402	CCpro 40	200	430	400	450	496	8	12	6
1CC9451	CCpro 45	200	430	450	500	546	8	12	7
1CC9502	CCpro 50	200	450	500	560	598	12	12	8
1CC9561	CCpro 56	200	450	560	620	658	12	12	9
1CC9632	CCpro 63	240	490	630	690	730	12	12	11
1CC9712	CCpro 71	280	530	710	770	810	16	12	13
1CC9802	CCpro 80	240	590	800	860	910	16	12	20
1CC9901	CCpro 90	340	690	900	970	1030	16	16	31
1CC9912	CCpro 100	410	760	1000	1070	1130	16	16	39
1CC9921	CCpro 112	410	760	1120	1190	1250	20	16	58
1CC9927	CCpro 125	410	760	1250	1320	1380	20	16	65
1CC9930	CCpro 140	510	960	1415	1470	1540	20	16	88
1CC9931	CCpro 160	510	960	1615	1680	1730	24	18	98

Dimensioni in mm | Dimensions in mm



CCst | STAFFE DI SOSTEGNO | SUPPORT FEET F400

Consentono l'ancoraggio del ventilatore a pavimento o soffitto. Realizzate in lamiera d'acciaio e verniciate a polveri epossipoliestiriche.

Suitable to fasten the fan on the floor or to the ceiling. Manufactured in steel sheet and protected against atmospheric agents by epoxy paint.

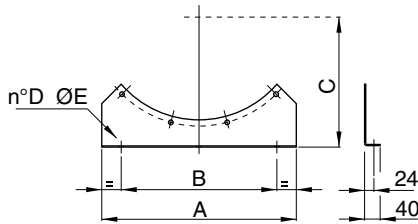

Code*	Tipo Type	A	B	C	D	ØE	Kg**
1ST0310	CCst 31	320	200	280	2	10	1,1
1ST0350	CCst 35	350	250	300	2	10	1,25
1ST0400	CCst 40	400	300	320	2	10	1,3
1ST0450	CCst 45	450	350	350	2	10	1,5
1ST0500	CCst 50	500	400	380	2	10	2,1
1ST0560	CCst 56	560	460	410	2	10	2,5
1ST0630	CCst 63	630	480	450	2	10	2,8
1ST0710	CCst 71	710	550	490	2	10	3,1
1ST0800	CCst 80	800	660	540	3	14	3,7
1ST0900	CCst 90	900	760	600	3	14	4,5
1ST1000	CCst 100	1000	860	640	3	14	4,8
1ST1120	CCst 112	1120	980	710	3	14	6,8
1ST1250	CCst 125	1250	950	770	3	14	7,8
1ST1400	CCst 140	1400	1100	850	3	14	11
1ST1600	CCst 160	1600	1300	960	3	16	21,5

Dimensioni in mm - * Codice della coppia - ** Peso di una staffa
Dimensions in mm - Item code of the set of 2 - Weight of a single support

CCga-HT | GIUNTO ANTIVIBRANTE | FLEXIBLE CONNECTORS F400

Impedisce la propagazione delle vibrazioni sulla canalizzazione. Costruito con due flange in lamiera d'acciaio, realizzate a norma UNI ISO 6580 - EUROVENT per il fissaggio al ventilatore e al canale, ed un nastro di collegamento flessibile e robusto. Adatto all'utilizzo ad alte temperature. Parti in lamiera verniciate a polveri epossipoliestiriche.

It prevents the propagation of vibrations along the ducted system. Manufactured with two flanges in steel sheet, according to UNI ISO 6580 - EUROVENT standard for fixing to the fan and to the duct, and a strong flexible fabric joint. Suitable for high temperature working. Components in steel sheet protected against atmospheric agents by epoxy paint.

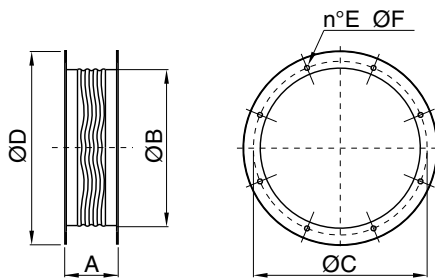

Code	Tipo Type	A	ØB	ØC	ØD	E	ØF	Kg
1SU5313	CCga 31	200	305	355	395	8	10	3,7
1SU5351	CCga 35	200	355	395	446	8	10	4,2
1SU5401	CCga 40	200	400	450	496	8	12	4,6
1SU5451	CCga 45	200	450	500	546	8	12	5,2
1SU5501	CCga 50	200	500	560	598	12	12	5,7
1SU5562	CCga 56	200	560	620	658	12	12	6,8
1SU5632	CCga 63	200	630	690	730	12	12	7,6
1SU5711	CCga 71	200	710	770	810	16	12	8,4
1SU5802	CCga 80	200	800	860	910	16	12	9,5
1SU5901	CCga 90	200	900	970	1030	16	16	10,8
1SU6001	CCga 100	200	1000	1070	1130	16	16	12,5
1SU5910	CCga 112	200	1120	1190	1250	20	16	14,1
1SU5911	CCga 125	200	1250	1320	1380	20	16	15,8
1SU6140	CCga 140	200	1415	1470	1540	20	16	38
1SU6160	CCga 160	200	1615	1680	1730	24	18	44

Dimensioni in mm | Dimensions in mm



BDD | SERRANDA DI CHIUSURA | BACKDRAUGHT DAMPER F400

Serrande di chiusura che consentono il ritorno delle alette in posizione tappata. Evitano inutili dispersioni di calore e richiedono un'irrelevante perdita di carico. Le alette della serranda si aprono con la depressione dell'aria generata dal ventilatore in moto. Si chiudono per gravità al suo spegnimento nelle versioni "V" (Flusso dell'aria verticale) e con l'aiuto di molle nelle versioni "H" (Flusso dell'aria orizzontale). Cassa è realizzata in lamiera verniciata e alette in lamiera zincata.

Backdraught damper that allow the return of the flaps in closed position. They avoid heat dispersion when the fan is off and require a negligible opening pressure. The shutter flaps are opened by the air depression produced by the fan when working. They shut down by gravity when the fan is switched off in the "V" versions (Vertical flow discharge) and thanks to springs in the "H" versions (Horizontal flow discharge).

Casing in painted steel sheet and flaps in galvanized steel sheet.

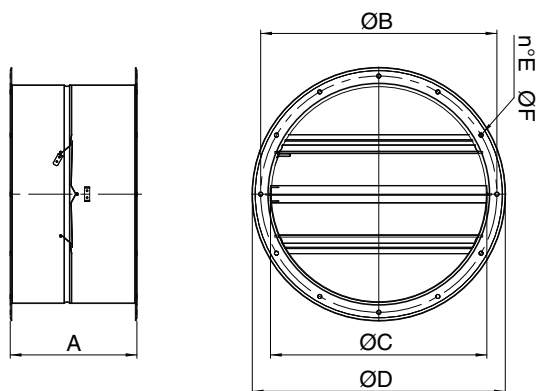

Code	Flusso* Flow	Tipo Type	ØA	ØB	ØC	ØD	E	ØF
1SE9247	H	BDD 400	350	450	405	500	8	12
1SE9262	V							
1SE9248	H	BDD 450	420	500	455	560	8	12
1SE9263	V							
1SE9249	H	BDD 500	370	560	505	610	12	12
1SE9264	V							
1SE9250	H	BDD 560	370	620	565	670	12	12
1SE9265	V							
1SE9251	H	BDD 630	370	690	635	740	12	12
1SE9266	V							
1SE9252	H	BDD 710	430	770	708	812	16	12
1SE9267	V							
1SE9253	H	BDD 800	450	860	808	912	16	12
1SE9268	V							
1SE9254	H	BDD 900	450	970	908	1012	16	16
1SE9269	V							
1SE9255	H	BDD 1000	400	1070	1010	1122	16	16
1SE9270	V							
1SE9256	H	BDD 1120	470	1190	1130	1242	20	16
1SE9271	V							
1SE9257	H	BDD 1250	470	1320	1260	1372	20	16
1SE9272	V							
1SE9258	H	BDD 1400	470	1460	1410	1522	20	16
1SE9273	V							

* H = Flusso dell'aria orizzontale del ventilatore - Horizontal flow discharge of the fan
V = Flusso dell'aria verticale del ventilatore - Vertical flow discharge of the fan

CCf | CONTROFLANGIA | COUNTER FLANGE F400

Piastra a forma di anello provvista di fori a norma UNI ISO 6580 - EUROVENT. Viene utilizzata per facilitare il collegamento tra il canale ed il ventilatore.

Ring plate with holes according to UNI ISO6580 - EUROVENT standard, compatible with fan flange. It is used for easier connection between the CC fan and the duct.

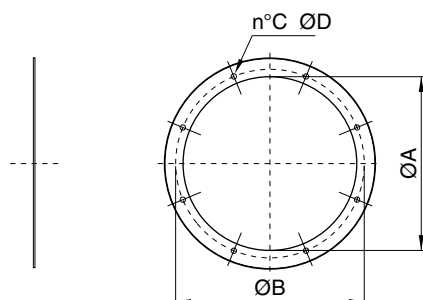

Code	Tipo Type	ØA	ØB	C	ØD	Kg
5B01031	CCf 31	315	355	8	10	1,2
5B01035	CCf 35	350	395	8	10	1,5
5B01040	CCf 40	400	450	8	12	1,7
5B01045	CCf 45	450	500	8	12	1,9
5B01050	CCf 50	500	560	12	12	2,1
5B01056	CCf 56	560	620	12	12	2,4
5B01063	CCf 63	630	690	12	12	2,7
5B01071	CCf 71	710	770	16	12	3,3
5B01081	CCf 80	800	860	16	12	3,7
5B01092	CCf 90	900	970	16	16	4,7
5B01110	CCf 100	1000	1070	16	16	5,2
5B01212	CCf 112	1120	1190	20	16	6,5
5B01210	CCf 125	1250	1320	20	16	8
-	CCf 140	1415	1470	20	16	10
-	CCf 160	1615	1680	24	18	12

Dimensioni in mm - 1400/1600: codice a richiesta
Dimensions in mm - item codes upon request



CCfc | CONTROFLANGIA CON COLLARE | COUNTER FLANGE WITH COLLAR F400

Controflangia a forma di anello con collare, provvista di fori a norma UNI ISO 6580 - EUROVENT. Viene utilizzata per facilitare il collegamento tra il canale ed il ventilatore.

Counter flange with addition of 80 mm of round duct. It is used for easier connection between the CC fan and the duct.

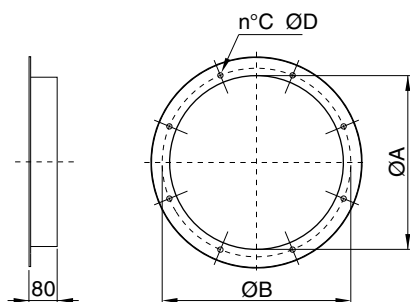

Code	Tipo Type	ØA	ØB	C	ØD	Kg
5B01531	CCfc 31	305	355	8	10	1,3
5B01535	CCfc 35	355	395	8	10	1,5
5B01540	CCfc 40	405	450	8	12	1,7
5B01545	CCfc 45	455	500	8	12	2
5B01550	CCfc 50	505	560	12	12	2,2
5B01556	CCfc 56	565	620	12	12	2,5
5B01563	CCfc 63	635	690	12	12	2,9
5B01571	CCfc 71	708	770	16	12	3,3
5B01580	CCfc 80	808	860	16	12	3,8
5B01590	CCfc 90	908	970	16	16	4,2
5B01600	CCfc 100	1010	1070	16	16	5
5B01620	CCfc 112	1130	1190	20	16	5,8
5B01625	CCfc 125	1260	1320	20	16	6,5
-	CCfc 140	1415	1470	20	16	10
-	CCfc 160	1615	1680	24	18	12

Dimensioni in mm | Dimensions in mm

CCot | TERMINALE CON RETE | OUTLET TERMINAL

Terminale parapigioggia con rete di protezione.
Outlet terminal with protection guard.

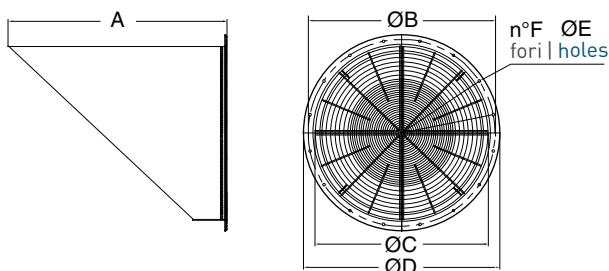

Code	Tipo Type	ØA	ØB	ØC	ØD	ØE	F	Kg
5TR0500	CCot 400	550	450	400	503	8	12	10
5TR0501	CCot 450	600	500	450	553	8	12	11
5TR0502	CCot 500	655	560	500	603	12	12	12,5
5TR0503	CCot 560	710	620	560	663	12	12	15
5TR0504	CCot 630	785	690	630	733	12	12	18
5TR0505	CCot 710	865	770	710	813	16	12	22
5TR0506	CCot 800	950	860	800	903	16	12	39
5TR0507	CCot 900	1050	970	900	1013	16	16	48
5TR0508	CCot 1000	1200	1070	1000	1113	16	16	80
5TR0509	CCot 1120	1325	1190	1120	1233	20	16	97
5TR0510	CCot 1250	1455	1320	1250	1367	20	16	118

Dimensioni in mm | Dimensions in mm

Kit TAV HT | CONVOGLIATORE VERTICALE | CONVEYOR FOR VERTICAL DISCHARGE F400

Convogliatore esterno per espulsione verticale costituito da una base in lamiera verniciata con vernici a polveri epossipoliestiriche e pannelli verticali in lamiera zincata.

Comprende:

- Serranda automatica con alette in alluminio a doppio battente, rivestite di materiale fonoassorbente.
- Piastra di appoggio in lamiera verniciata con vernici a polveri epossipoliestiriche.
- Rete di protezione sulla mandata realizzata DIN 31001 e protetta contro gli agenti atmosferici.

Outer conveyor for vertical exhaust with epoxy painted steel sheet base and with vertical panels in galvanized steel sheet.

The kit includes:

- Double wing aluminium gravity shutters, acoustically lined.
- Support plate in epoxy painted steel sheet.
- Weatherproof outlet protection guard according to norm DIN 31001 and protected against atmospheric agents.

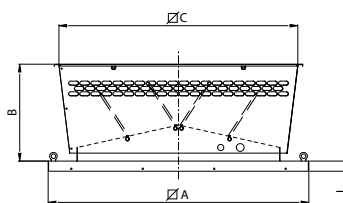

Code	Tipo Type	A	B	C	I	Kg
0807	TAV-HT 800	1285	750	1320	50	95
0907	TAV-HT 900	1285	750	1320	50	95
1007	TAV-HT 1000	1585	600	1530	60	125
1127	TAV-HT 1120	1585	600	1530	60	125
1257	TAV-HT 1250	1843	685	1850	85	160
1407	TAV-HT 1400	1843	685	1850	85	160

Dimensioni in mm | Dimensions in mm



Installabile a tetto per ventilatori assiali intubati
Roof terminal for duct axial fans