



ERM-EX ATEX

Aspiratori elico-centrifughi a sicurezza aumentata Enhanced safety mixed flow fans



EN 14986:2017

Certificato | Certificate

TUV-A 18 ATEX 0052
TUV-A 18 ATEX 0055
TUV-A 18 ATEX 0054



DESCRIZIONE

Gli aspiratori serie ERM-EX sono i soli apparecchi elico-centrifughi in linea in esecuzione a sicurezza aumentata presenti sul mercato. Sono costruiti e certificati in conformità alla Direttiva ATEX 2014/34/UE e la EN 14986/2017. La particolare costruzione ne permette l'impiego in ambienti con atmosfera a rischio di esplosione come: locali batteria, tintorie, autorimesse, etc. Adatti a convogliare aria pulita ad una temperatura da -20°C a +50°C. La serie ERM-EX non prevede la regolazione della velocità.

CONSTRUZIONE

- Cassa e girante sono realizzate in materiale plastico antistatico e resistente agli urti.
- Collegamenti elettrici racchiusi in un contenitore esterno, con grado di protezione IP54.

MOTORE

Motore elettrico monofase, IP 54, classe B. Idoneo ad un funzionamento in servizio continuo. Esecuzione II 2G Ex eb, IIB+H2 T4 Gb [ERM-EX 18], T3 Gb [ERM-EX 22 e 25] secondo le norme EN 60079-0:2012 + A11:2013, EN 60079-7:2015, EN 14986:2017, EN ISO 80079-36:2016, EN ISO 80079-37:2016.

AVVERTENZE

La scelta del tipo di protezione del motore deve essere effettuata in funzione delle zone di pericolo e delle classi di aree pericolose in cui il ventilatore verrà installato. Solo le autorità preposte possono attribuire le classi e le zone di pericolo alle aree pericolose.

ACCESSORI

- Riduzione
- Rete di protezione
- Staffa di fissaggio.

DESCRIPTION

The ERM-EX fans are the only mixed flow in line series in increased safety execution available on the market. They are built and certified according to ATEX Directive 2014/34/UE and EN14986/2017. The particular construction allows the installation in hazardous environment as: battery rooms, dyeing-plants, garages, etc. Suitable to convey clean air with working temperature from -20°C to +50°C. The ERM-EX series are not suitable for regulation.

CONSTRUCTION

- Housing and impeller are manufactured in sparkproof plastic material resistant to the impacts.
- Electric connections enclosed in an external terminal box, resistant to atmospheric agents with IP54 protection degree.

MOTOR

Single-phase electric motor, IP 54, class B. Suitable for working in continuous service. Execution II 2G Ex eb, IIB+H2 T4 Gb [ERM-EX 18], T3 Gb [ERM-EX 22 and 25] according to EN 60079-0:2012 + A11:2013, EN 60079-7:2015, EN 14986:2017, EN ISO 80079-36:2016, EN ISO 80079-37:2016 standards.

ATTENTION

The choice of the motor protection type must be made in function of the zones of danger and the classes of hazardous areas, which the fan will be installed in. Only the competent authorities can attribute the classes and the zones of danger to the hazardous areas.

ACCESSORIES

- Reduction
- Protection guard
- Fixing clamps.

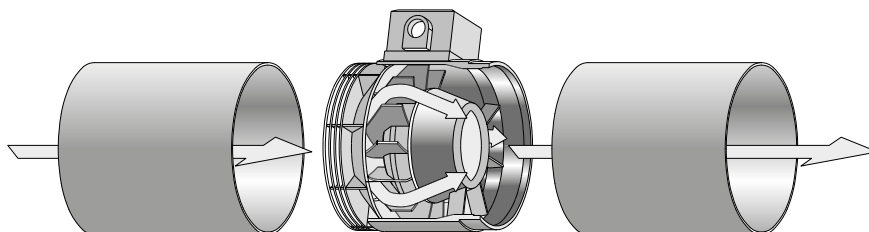

PRESTAZIONI | PERFORMANCE

ERM-EX

Frequenza 50Hz - Temperatura dell'aria 15°C - Pressione barometrica 760 mm Hg - Peso specifico dell'aria 1,22 Kg/m³
 Alimentazione 230V/1ph/50Hz
 Frequency 50Hz - Air temperature 15°C - Barometric pressure 760 mm Hg - Air specific weight 1,22 Kg/m³
 Power supply 230V/1ph/50Hz

Lp Livello di pressione sonora rilevato a 1,50 m in condizioni standard (vedi legenda a inizio catalogo)
 Sound pressure level measured at 1,50 m in standard conditions (see legend at the beginning of the catalogue)

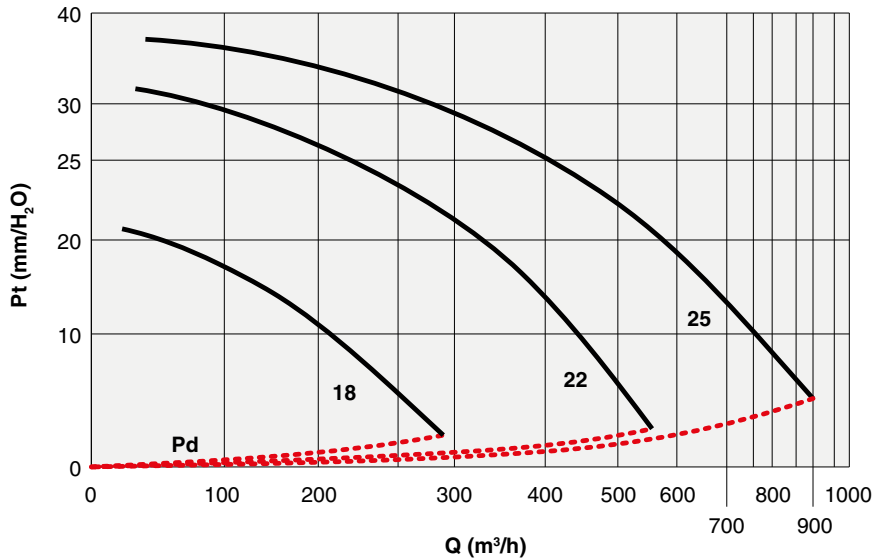

| Code | Tipo Type | Modello Model | U | rpm | Pm (kW) | In max (A) | IP/CL | Lw* dB(A) |
|---------|--------------|------------------|---|------|------------|---------------|-------|--------------|
| 2ME1000 | | 18 | M | 2760 | 0,06 | 0,28 | 54/B | 66 |
| 2ME1002 | ERM-EX | 22 | M | 2850 | 0,2 | 0,93 | 54/B | 73 |
| 2ME1004 | | 25 | M | 2890 | 0,3 | 1,42 | 54/B | 77 |

* A bocca libera | Free inlet

DIMENSIONI | DIMENSIONS mm

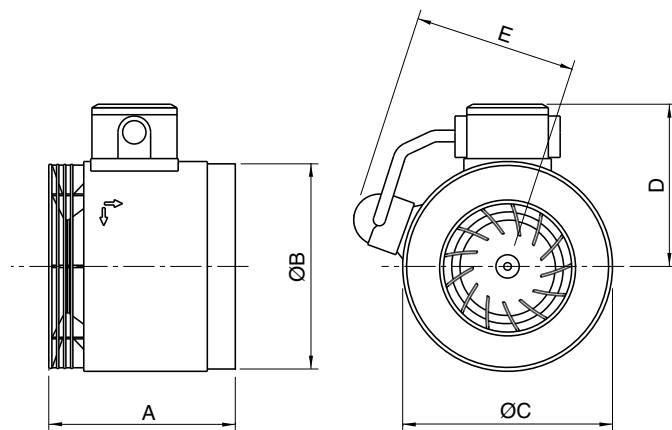

ERM-EX ATEX

| TIPO TYPE | A | ØB | ØC | D | E | Kg |
|-------------|-----|-----|-----|-----|-----|-----|
| ERM-EX 18 | 161 | 175 | 180 | 137 | 140 | 2 |
| ERM-EX 22 | 175 | 221 | 230 | 165 | 165 | 5 |
| ERM-EX 25 | 205 | 245 | 255 | 178 | 180 | 6,5 |

Pesi indicativi | Indicative weights



RIDUZIONE | REDUCTION

- Permette di raccordare la bocca di mandata al tubo
- Realizzato in materiale antistatico adatto agli ambienti a rischio di esplosione
- To connect the inlet side of the fan to the duct
- Made in antistatic material suitable for hazardous environments

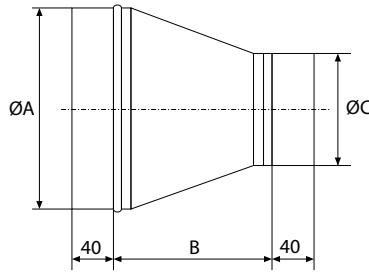

| Code | Tipo Type | ØA | B | ØC |
|---------|--------------|-----|-----|-----|
| 5RD1001 | 18/14 ERM-EX | 179 | 165 | 139 |
| 5RD1002 | 18/12 ERM-EX | 179 | 186 | 124 |
| 5RD1003 | 18/10 ERM-EX | 179 | 220 | 99 |
| 5RD1004 | 22/18 ERM-EX | 225 | 170 | 179 |
| 5RD1006 | 22/16 ERM-EX | 225 | 198 | 159 |
| 5RD1007 | 22/14 ERM-EX | 225 | 225 | 139 |
| 5RD1008 | 25/20 ERM-EX | 249 | 179 | 199 |
| 5RD1009 | 25/18 ERM-EX | 249 | 206 | 179 |

GRIGLIA DI PROTEZIONE | PROTECTION GUARD

- Rete di protezione adatta per entrambi i lati aspirante o premente
- Conforme alla norma DIN EN 294
- Realizzata in metallo
- Protection guard both for inlet and outlet sides of the fan
- Conformity to norm DIN EN 294
- Made in steel

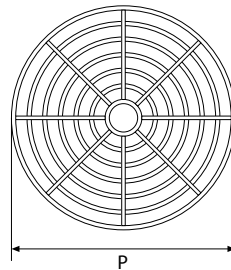

| Code | Tipo Type | P |
|---------|-------------|-----|
| 5GR1000 | ERM-EX 18 | 178 |
| 5GR1001 | ERM-EX 22 | 224 |
| 5GR1002 | ERM-EX 25 | 249 |

STAFFA DI FISSAGGIO | FIXING CLAMPS

- Per l'installazione dell'apparecchio a parete, a soffitto o da appoggio
- Installazione orizzontale o verticale
- Realizzata in lamiera zincata
- For wall, ceiling or basement installation
- Horizontal or vertical installation
- Made in galvanized steel sheet

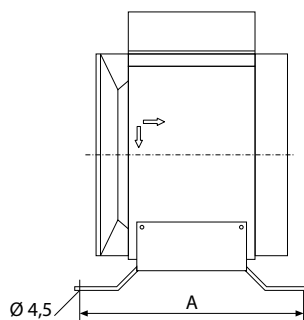
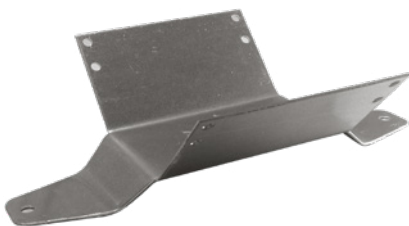

| Code | Tipo Type | A |
|---------|-------------|-----|
| 5SX0000 | ERM-EX 18 | 187 |
| 5SX0002 | ERM-EX 22 | 203 |
| 5SX0001 | ERM-EX 25 | 232 |