

PN-L INOX

Aspiratori centrifughi pale rovesce per aria pulita o leggermente polverosa

Backward curved blade centrifugal fans for clean or slightly dusty air



DESCRIZIONE

I ventilatori della serie **PN-L INOX** trovano la loro principale applicazione nell'impiantistica industriale e nel condizionamento.

GAMMA

Diametri da 400 a 630 mm
Portate da 4.700 a 32.400 m³/h
La serie prevede esecuzioni direttamente accoppiate (esecuzione 4) e a trasmissione (esecuzione 1, 9 e 12).

TEMPERATURA DI ESERCIZIO

Temperature da -10°C a +60°C nella configurazione standard, e fino a 300°C con costruzioni speciali.

COSTRUZIONE

- Cassa a a spirale, boccaglio di aspirazione e girante con pale rovesce curve realizzati in acciaio inox AISI 304/316L.
- Per esecuzione 1 - 9 - 12: supporto monoblocco realizzato in fusione di ghisa, con cuscinetti a sfera, progettati per agevolare le operazioni di lubrificazione. Cinghie di trasmissione, pulegge e supporto motore. Carter di protezione per le cinghie.

MOTORE

Motore asincrono trifase a norme internazionali IEC 60034, IEC 60072, EMC 2014/30/UE, LVD 2014/35/UE e marcato CE IP55, classe F, idonei ad un servizio S1 (funzionamento continuo a carico costante).

ACCESSORI

- Controflangia per bocca aspirante
- Controflangia per bocca premente
- Rete di protezione per bocca aspirante
- Rete di protezione per bocca premente
- Giunto antivibrante per bocca aspirante
- Giunto antivibrante per bocca premente

DESCRIPTION

The **PN-L INOX** series of fans are mainly used in industrial and air conditioning applications.

RANGE

Diameters from 400 to 630 mm
Airflow from 4,700 to 32,400 m³/h
The series includes directly coupled (version 4) and transmission versions (versions 1, 9 and 12).

OPERATING TEMPERATURE

Temperatures from -10°C to +60°C in the standard configuration, and up to 300°C with special constructions.

CONSTRUCTION

- Volute casing, suction nozzle and single inlet impeller with backward curved blades made of inox stainless steel AISI 304/316L.
- For execution 1 - 9 - 12: mono-block support in cast iron with ball bearings, designed for easy lubrication. Pulleys, belts and motor support. Belt protection guard.

MOTOR

Asynchronous three-phase motors according to international standards IEC 60034, IEC 60072, EMC 2014/30/UE, LVD 2014/35/UE, CE marked, IP 55, class F, suitable to S1 service (continuous working at constant load).

ACCESSORIES

- Inlet counter-flange
- Outlet counter-flange
- Inlet protection guard
- Outlet protection guard
- Inlet flexible connector
- Outlet flexible connector

VERSIONI | VERSIONS



PN-L

Versione per temperatura aria standard da -10 a +60°C
Version for standard air temperature from -10 to +60°C



PN-L ATEX

Versione antideflagrante secondo la Direttiva 2014/34/UE
Explosion-proof version according to Directive 2014/34/UE



PN-L AT

Versione idonea al trasporto di gas caldi, max 150°C (PN-L/AT es 4) e max 300°C (PN-L/AT es 1-12)
Version suitable for transporting hot gases, max. 150°C (PN-L/AT arrangement 4) and max. 300°C (PN-L/AT arrangement 1-12)

CAMPO D'IMPIEGO | OPERATION FIELD

PN-L INOX

Questo grafico ha il solo scopo di rappresentare le aree di funzionamento dei modelli disponibili. Per una selezione precisa utilizzare i grafici prestazionali presenti di seguito oppure contattate il nostro servizio tecnico commerciale.

This graph is only meant to represent the operating areas of the available models. For an accurate selection please use the performance graphs below or contact our technical sales department.

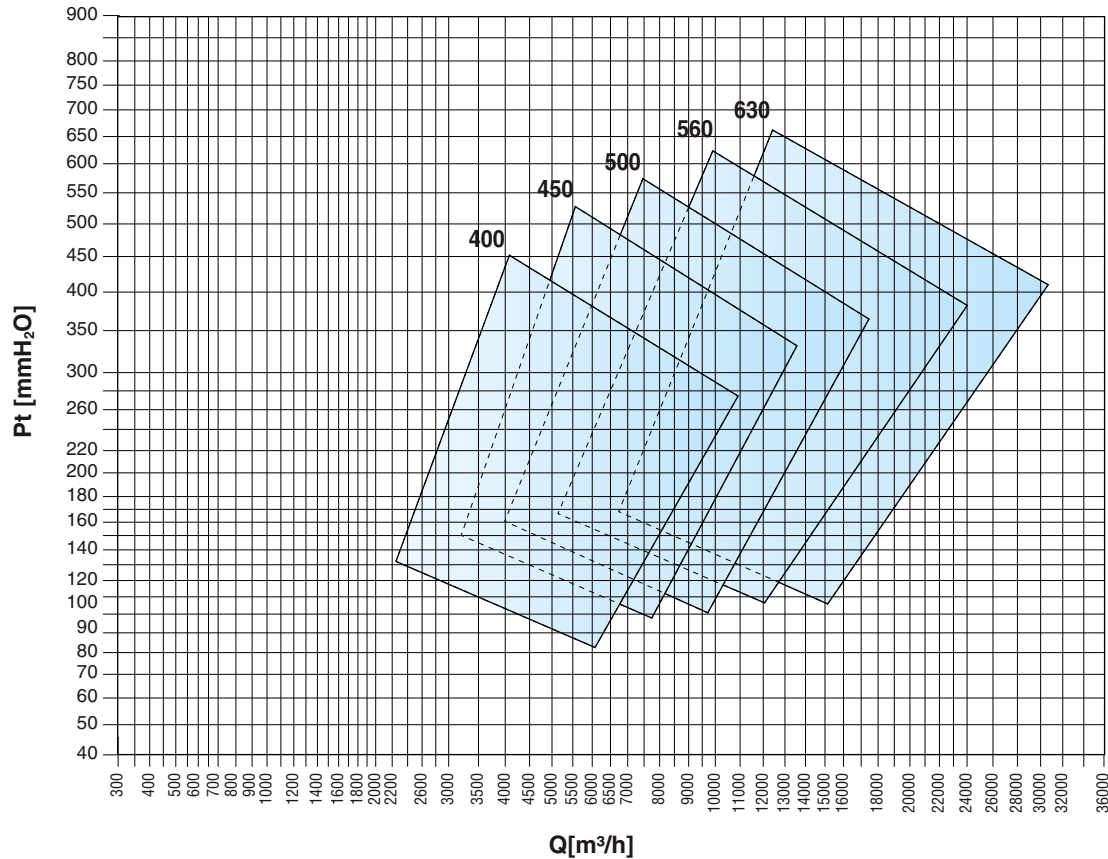

Grandezza ventilatore Fan size	RPM MAX		
	Classe I	Classe II	Classe III
PN-L INOX 400	3450	3900	4500
PN-L INOX 450 R	3150	3600	4250
PN-L INOX 450	3050	3500	4000
PN-L INOX 500 R	2900	3300	3850
PN-L INOX 500	2750	3150	3700
PN-L INOX 560 R	2550	2900	3550
PN-L INOX 560	2450	2800	3400
PN-L INOX 630 R	2300	2600	3200
PN-L INOX 630	2200	2800	3000

VALORI RPM VALIDI FINO A 60°C RPM VALUES VALID UP TO 60°C

Fra Between	E And	Declassare velocità Degrade speed
60°C	100°C	4%
100°C	150°C	10%
150°C	200°C	16%
200°C	250°C	23%
250°C	300°C	30%
300°C	350°C	37%
350°C	400°C	45%
400°C	450°C	54%
450°C	500°C	64%

PRESTAZIONI | PERFORMANCE

PN-L INOX

Le curve prestazionali rappresentate nel presente catalogo sono state ricavate eseguendo prove sui ventilatori in accordo alla normativa ISO 5801 "Metodi di prova e condizioni di accettazione" (che sostituisce la ISO 1053:1995 ed è in accordo con la UNI EN ISO 5801:2009). Per eseguire le prove i ventilatori sono stati installati secondo quanto previsto per la categoria B: con bocca d'aspirazione libera e bocca premente collegata al banco prova. L'efficienza dei ventilatori è conforme all'obiettivo del regolamento (UE) N.327/2011, come richiesto dalla Direttiva 2009/125/CE.

The performance curves given in this catalogue were calculated by performing tests on fans in compliance with ISO 5801 "Test methods and terms of acceptance" [which replaces UNI 10531:1995 and complies with UNI EN ISO 5801:2009]. To carry out the tests the fans were installed in compliance with the requirements for category B: with free inlet and outlet connected to the test station. The fan efficiency conforms to the objective of Regulation (EU) N.327/2011, as required by Directive 2009/125/EC.

LW La determinazione del livello di potenza sonora è stata condotta secondo la norma UNI EN ISO 3746:1997 (Metodo di controllo con una superficie avvolgente su un piano riflettente). Alle misure sono state applicate correzioni in funzione del rumore di fondo e del riverbero ambientale. Measurement of the sound power level was carried out in compliance with UNI EN ISO 3746:1997 (Survey method using an enveloping measurement surface over a reflecting plane). The measurements were subjected to corrections to take account of background noise and ambient reverberation levels.

PN-L INOX 402

Code	Tipo Type	Modello Model	U	P	Pm (kW)	In (A)	IE3	IP/CL
A RICHIESTA UPON REQUEST	PN-L INOX	402 R	T	2	4	7,10	✓	55/F
		402	T	2	5,5	9,70	✓	55/F

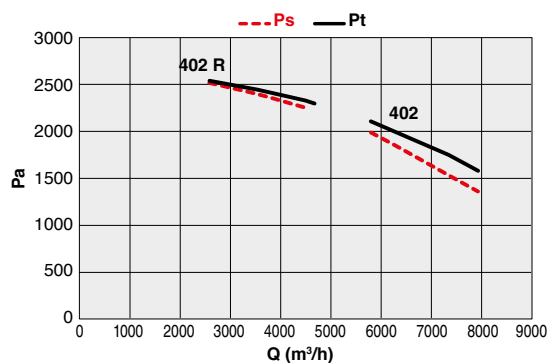

PN-L INOX 452

Code	Tipo Type	Modello Model	U	P	Pm (kW)	In (A)	IE3	IP/CL
A RICHIESTA UPON REQUEST	PN-L INOX	452 R	T	2	7,5	13,10	✓	55/F
		452 Br	T	2	7,5	13,10	✓	55/F
		452	T	2	11	18,70	✓	55/F

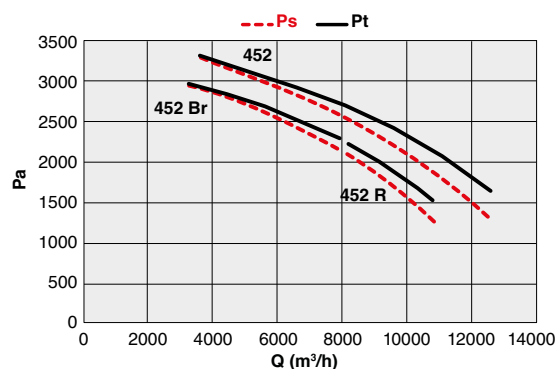

PN-L INOX 500

Code	Tipo Type	Modello Model	U	P	Pm (kW)	In (A)	IE3	IP/CL
A RICHIESTA UPON REQUEST	PN-L INOX	500 R	T	2	11	18,70	✓	55/F
		502	T	2	15	25,40	✓	55/F

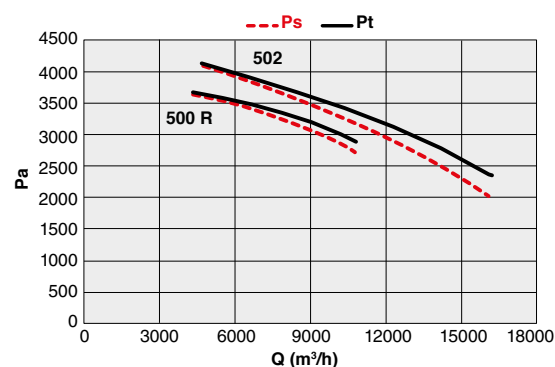

PN-L INOX 560

Code	Tipo Type	Modello Model	U	P	Pm (kW)	In (A)	IE3	IP/CL
A RICHIESTA UPON REQUEST	PN-L INOX	562 R	T	2	18,5	30,80	✓	55/F
		562	T	2	22	37,40	✓	55/F
		562 Br	T	2	22	37,40	✓	55/F
		562 B	T	2	30	51,00	✓	55/F

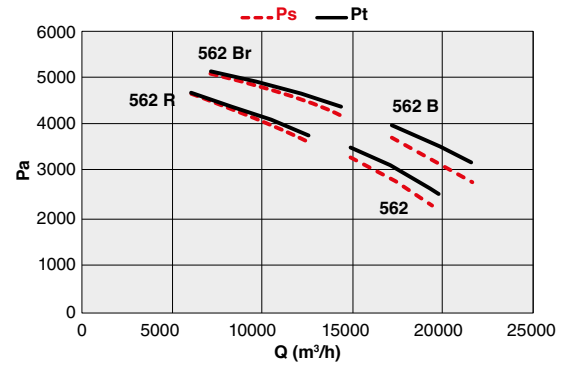

PN-L INOX 600

Code	Tipo Type	Modello Model	U	P	Pm (kW)	In (A)	IE3	IP/CL
A RICHIESTA UPON REQUEST	PN-L INOX	632 R	T	2	30	51,00	✓	55/F
		632	T	2	37	61,90	✓	55/F
		632 Br	T	2	37	61,90	✓	55/F
		632 B	T	2	45	76,80	✓	55/F
		634 R	T	4	4	7,60	✓	55/F
		634	T	4	5,5	6,60	✓	55/F

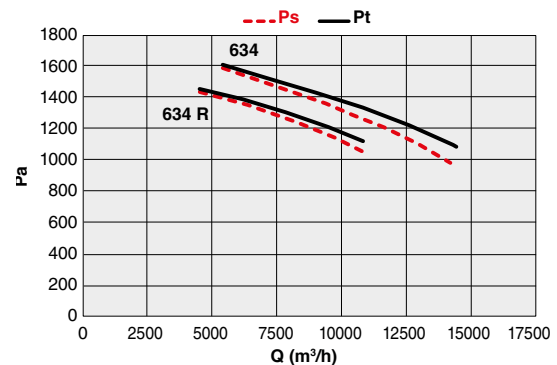
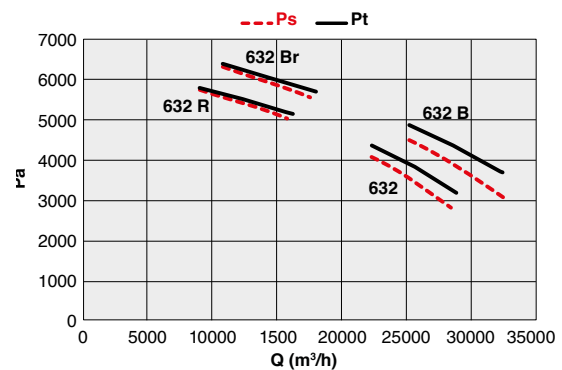

ESECUZIONE 4 ARRANGEMENT 4

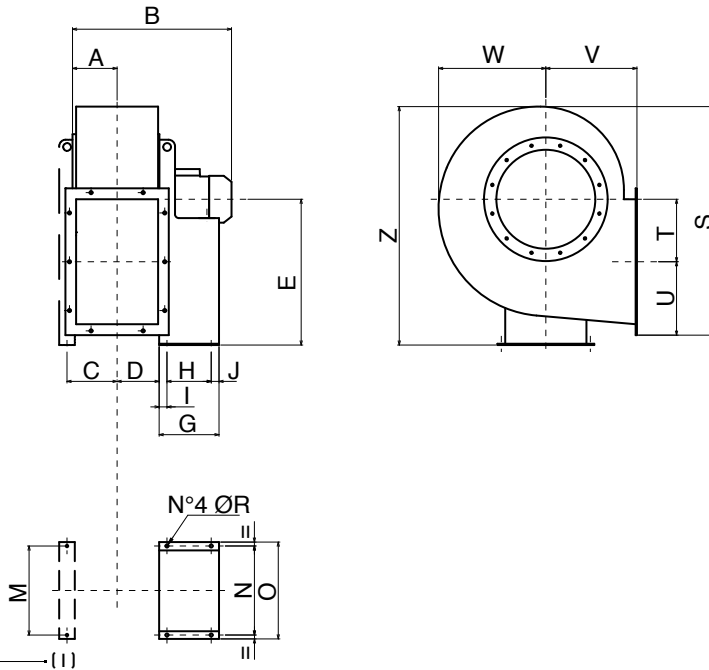

PN-L INOX 400-500

TIPO TYPE	A	B	C	D	E	G	H	I	J	M	N	O	ØR	Z	S	T	U	V	W
PN-L INOX 402 R	147	665	174	147	500	285	197	34	54	445	289	324	12	811	798	245	242	285	400
PN-L INOX 402	147	665	174	147	500	345	237	44	64	445	289	324	12	811	798	245	242	285	400
PN-L INOX 452 R	163	751	191	165	560	345	237	44	64	495	337	372	12	914	895	275	267	320	445
PN-L INOX 452 Br	163	751	191	165	560	345	237	44	64	495	337	372	12	914	895	275	267	320	445
PN-L INOX 452	163	751	191	165	560	446	337	55	54	495	337	372	12	914	895	275	267	320	445
PN-L INOX 502 R	183	913	23	185	600	446	337	55	54	545	395	440	14	1001	997	303	294	360	502
PN-L INOX 502	183	913	23	185	600	446	337	55	54	545	395	440	14	1001	997	303	294	360	502

ESECUZIONE 4 ARRANGEMENT 4

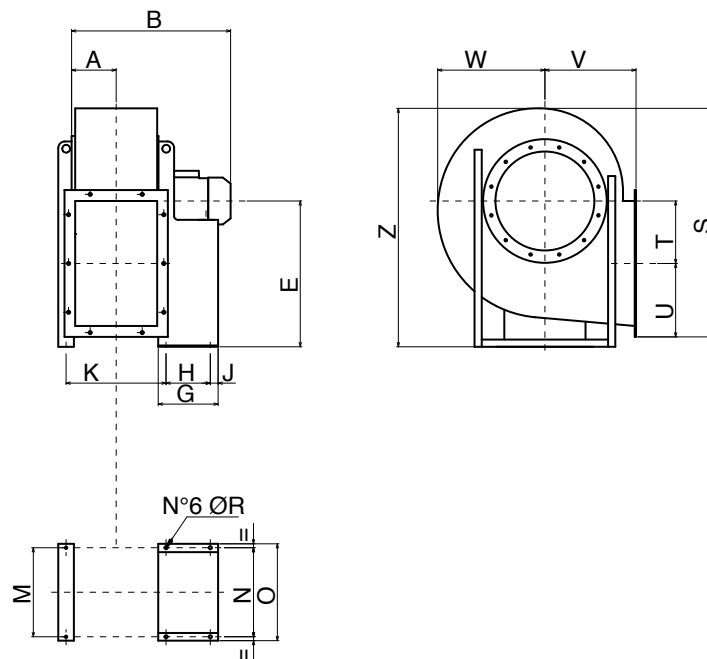

PN-L INOX 560-600

TIPO TYPE	A	B	E	G	H	J	K	N	O	ØR	M	Z	S	T	U	V	W
PN-L INOX 562 R	205	1036	670	440	337	54	488	395	440	14	632	1154	1151	332	335	400	570
PN-L INOX 562	205	1072	670	464	357	37	509	434	488	17	632	1154	1151	332	335	400	570
PN-L INOX 562 Br	205	1072	670	464	357	37	509	434	488	17	632	1154	1151	332	335	400	570
PN-L INOX 562 B	205	1072	670	464	357	39	509	434	488	17	632	1154	1151	332	335	400	570
PN-L INOX 632 R	230	1179	750	509	381	48	568	506	568	19	702	1290	1282	373	369	450	630
PN-L INOX 632	230	1179	750	509	381	48	568	506	568	19	702	1290	1282	373	369	450	630
PN-L INOX 632 Br	230	1179	750	509	381	48	568	506	568	19	702	1290	1282	373	369	450	630
PN-L INOX 632 B	230	1179	750	509	381	39	568	506	568	19	702	1290	1282	373	369	450	630
PN-L INOX 634 R	230	845	750	280	197	54	517	289	324	12	702	1290	1282	373	369	450	630
PN-L INOX 634	230	845	750	340	237	64	527	337	372	12	702	1290	1282	373	369	450	630

ESECUZIONE 1 ARRANGEMENT 1

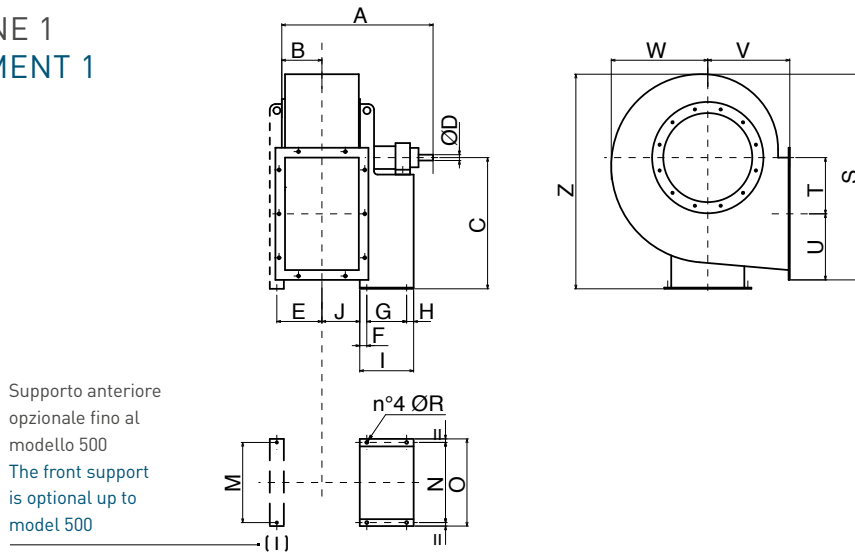

PN-L INOX 400-500

TIPO TYPE	A	B	C	ØD	E	F	G	H	I	J	M	N	O	ØR	S	T	U	V	W	Z
PN-L INOX 400	910	147	500	38	174	50	407	28	485	147	445	355	400	14	798	245	242	285	400	811
PN-L INOX 450	930	163	560	38	191	50	407	28	485	165	495	355	400	14	895	275	267	320	445	914
PN-L INOX 500	1084	183	600	42	23	50	477	33	560	185	545	364	418	17	997	303	294	360	502	1001

ESECUZIONE 1 ARRANGEMENT 1

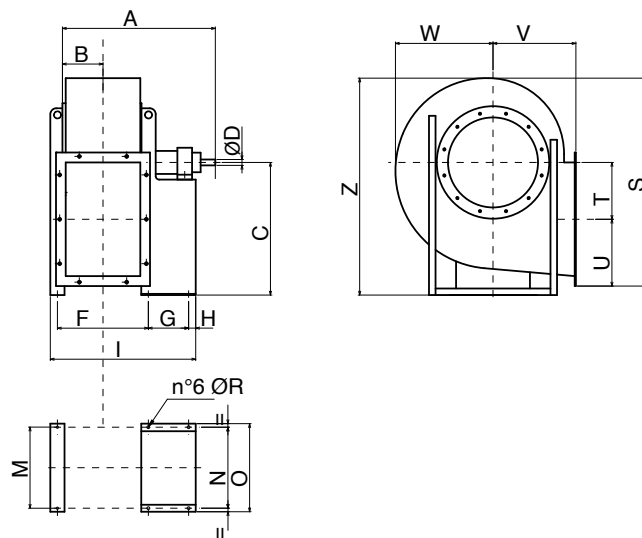

PN-L INOX 560-630

TIPO TYPE	A	B	C	ØD	F	G	H	I	M	N	O	ØR	S	T	U	V	W	Z
PN-L INOX 560	1177	205	670	48	488	477	33	1021	632	632	692	17	1151	332	335	400	570	1155
PN-L INOX 630	1233	230	750	48	537	477	33	1070	702	702	762	17	1282	373	369	450	630	1290

BOCCA ASPIRANTE | INTEL CONE

TIPO TYPE	ØR	ØS	ØT	n° F	Ø G
PN-L INOX 400	405	448	485	12	12
PN-L INOX 450	455	497	535	12	12
PN-L INOX 500	505	551	585	12	14
PN-L INOX 560	565	629	665	12	14
PN-L INOX 630	635	698	735	12	14

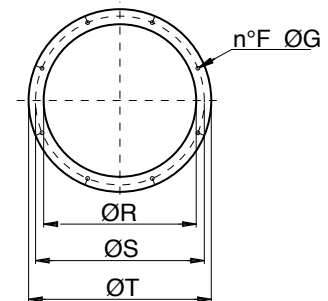

BOCCA PREMENTE | OUTLET CONE

TIPO TYPE	A	B	a1	b1	a2	b2	N1 x p	N2 x p	n° D	Ø E
PN-L INOX 400	404	288	448	332	484	368	2 x 125	3 x 125	14	12
PN-L INOX 450	453	322	497	366	533	402	2 x 125	3 x 125	14	12
PN-L INOX 500	507	361	551	405	587	441	2 x 125	3 x 125	14	12
PN-L INOX 560	569	404	629	464	669	504	2 x 160	3 x 160	14	14
PN-L INOX 630	638	453	698	513	738	553	2 x 160	3 x 160	14	14

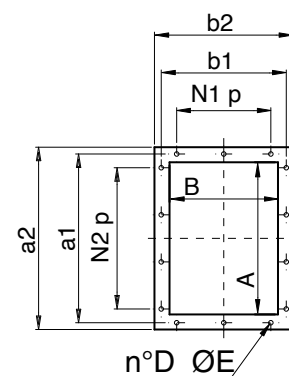

DIMENSIONI E ORIENTAMENTI mm

PN-L INOX

DIMENSIONS AND DISCHARGE ANGLES

Dimensioni dei modelli secondo l'orientamento.

Dimensions of models according to the discharge angle.

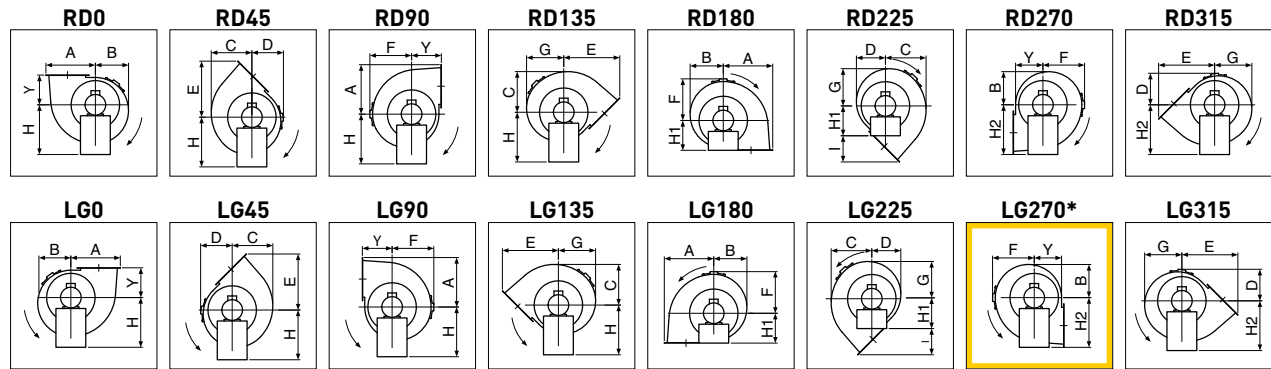

* Versione standard | Standard version.

TIPO TYPE	A	B	C	D	E	F	G	I	Y	H	H1	H2
PN-L INOX 400	487	311	387	306	543	400	353	258	285	500	285	500
PN-L INOX 450	542	354	435	342	609	445	398	289	320	560	320	560
PN-L INOX 500	597	401	490	380	676	502	450	316	360	600	360	600
PN-L INOX 560	667	485	555	425	754	570	542	354	400	670	400	670
PN-L INOX 630	742	540	619	476	843	630	603	393	450	750	450	750

PESI | WEIGHTS

Modello Model	Kg*
PN-L INOX 402 R	106
PN-L INOX 402	106
PN-L INOX 452 R	124
PN-L INOX 452 Br	127
PN-L INOX 452	127

Modello Model	Kg*
PN-L INOX 502 R	187
PN-L INOX 502	199
PN-L INOX 562 R	220
PN-L INOX 562	273
PN-L INOX 562 Br	275
PN-L INOX 562 B	273

Modello Model	Kg*
PN-L INOX 632 R	387
PN-L INOX 632	387
PN-L INOX 632 Br	389
PN-L INOX 632 B	387
PN-L INOX 634 R	180
PN-L INOX 634	202

* Pesi indicativi | Indicative weights



LATO ASPIRANTE | INLET SIDE

Flangia - Rete - Giunto | Flange - Guard - Flexible connector

FLANGIA | FLANGE

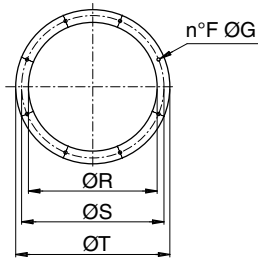

RETE | GUARD

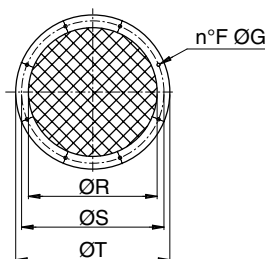

GIUNTO | FLEXIBLE CONNECTOR

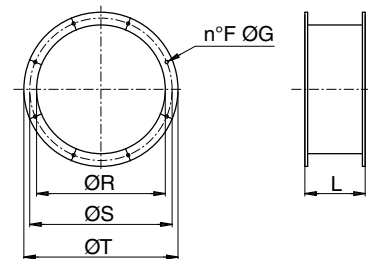

Flangia Flange	Rete Guard	Giunto Connector	Tipo Type	ØR	ØS	ØT	F	ØG	L
5B01347	5RE5606	5SU1102	400	405	448	485	12	12	145
5B08105	5RE1046	5SU1406	450	455	497	535	12	12	145
5B01380	5RE1180	5SU1180	500	505	551	585	12	14	180
5B08087	5RE1016	5SU8004	560	565	629	665	12	14	180
5B01391	5RE1013	5SU9000	630	635	698	735	12	14	180

Dimensioni in mm | Dimensions in mm

LATO PREMENTE | OUTLET SIDE

Flangia - Rete - Giunto | Flange - Guard - Flexible connector

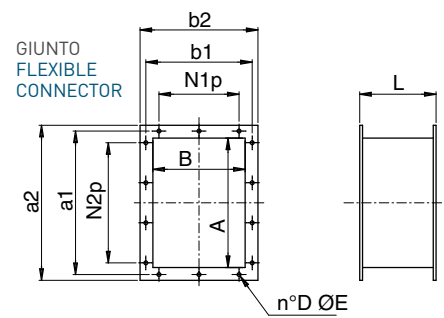
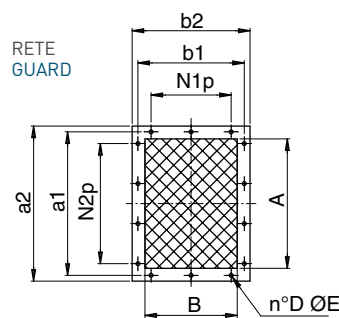
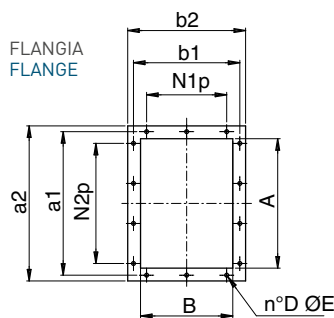

Flangia Flange	Rete Guard	Giunto Connector	Tipo Type	A	B	a1	b1	a2	b2	N1 x p	N2 x p	n° D	ø E	L
5B01344	5RE1020	5SU4023	400	404	288	448	332	484	368	2 x 125	3 x 125	14	12	145
5B01348	5RE1006	5SU5601	450	453	322	497	366	533	402	2 x 125	3 x 125	14	12	145
5B01381	5RE1024	5SU1181	500	507	361	551	405	587	441	2 x 125	3 x 125	14	12	145
5B08104	5RE1004	5SU4021	560	569	404	629	464	669	504	2 x 160	3 x 160	14	14	180
5B01310	5RE1035	5SU1402	630	638	453	698	513	738	553	2 x 160	3 x 160	14	14	180

Dimensioni in mm | Dimensions in mm