

PR-F INOX

Aspiratori centrifughi pale rovesce per aria pulita o polverosa

Backward curved blade centrifugal fans for clean or dusty air



DESCRIZIONE

I ventilatori della serie **PR-F INOX** trovano la loro principale applicazione nell'impiantistica industriale e nel condizionamento.

GAMMA

Diametri da 250 a 1.400 mm
Portate da 1.000 a 110.000 m³/h
La serie prevede esecuzioni direttamente accoppiate (esecuzione 4) e a trasmissione (esecuzione 1, 9 e 12).

TEMPERATURA DI ESERCIZIO

Temperature da -10°C a +60°C nella configurazione standard, e fino a 300°C con costruzioni speciali.

COSTRUZIONE

- Cassa a a spirale, boccaglio di aspirazione e girante con pale rovesce curve realizzati in acciaio inox AISI 304/316L.
- Per esecuzione 1 - 9 - 12: supporto monoblocco realizzato in fusione di ghisa, con cuscinetti a sfera, progettati per agevolare le operazioni di lubrificazione. Cinghie di trasmissione, pulegge e supporto motore. Carter di protezione per le cinghie.

MOTORE

Motore asincrono trifase a norme internazionali IEC 60034, IEC 60072, EMC 2014/30/UE, LVD 2014/35/UE e marcato CE IP55, classe F, ideati ad un servizio S1 (funzionamento continuo a carico costante).

ACCESSORI

- Controflangia per bocca aspirante
- Controflangia per bocca premente
- Rete di protezione per bocca aspirante
- Rete di protezione per bocca premente
- Giunto antivibrante per bocca aspirante
- Giunto antivibrante per bocca premente

DESCRIPTION

The **PR-F INOX** series of fans are mainly used in industrial and air conditioning applications.

RANGE

Diameters from 250 to 1,400 mm
Airflow from 1,000 to 110,000 m³/h
The series includes directly coupled (version 4) and transmission versions (versions 1, 9 and 12).

OPERATING TEMPERATURE

Temperatures from -10°C to +60°C in the standard configuration, and up to 300°C with special constructions.

CONSTRUCTION

- Volute casing, suction nozzle and single inlet impeller with backward curved blades made of inox stainless steel AISI 304/316L.
- For execution 1 - 9 - 12: mono-block support in cast iron with ball bearings, designed for easy lubrication. Pulleys, belts and motor support. Belt protection guard.

MOTOR

Asynchronous three-phase motors according to international standards IEC 60034, IEC 60072, EMC 2014/30/UE, LVD 2014/35/UE, CE marked, IP 55, class F, suitable to S1 service (continuous working at constant load).

ACCESSORIES

- Inlet counter-flange
- Outlet counter-flange
- Inlet protection guard
- Outlet protection guard
- Inlet flexible connector
- Outlet flexible connector

VERSIONI | VERSIONS



PR-F

Versione per temperatura aria standard da -10 a +60°C
Version for standard air temperature from -10 to +60°C



PR-F ATEX

Versione antideflagrante secondo la Direttiva 2014/34/UE
Explosion-proof version according to Directive 2014/34/UE



PR-F AT

Versione idonea al trasporto di gas caldi, max 150°C (PR-F/AT es 4) e max 300°C (PR-F/AT es 1-12)
Version suitable for transporting hot gases, max. 150°C (PR-F/AT arrangement 4) and max. 300°C (PR-F/AT arrangement 1-12)

CAMPO D'IMPIEGO | OPERATION FIELD

PR-F INOX

Questo grafico ha il solo scopo di rappresentare le aree di funzionamento dei modelli disponibili. Per una selezione precisa utilizzare i grafici prestazionali presenti di seguito oppure contattate il nostro servizio tecnico commerciale.

This graph is only meant to represent the operating areas of the available models. For an accurate selection please use the performance graphs below or contact our technical sales department.

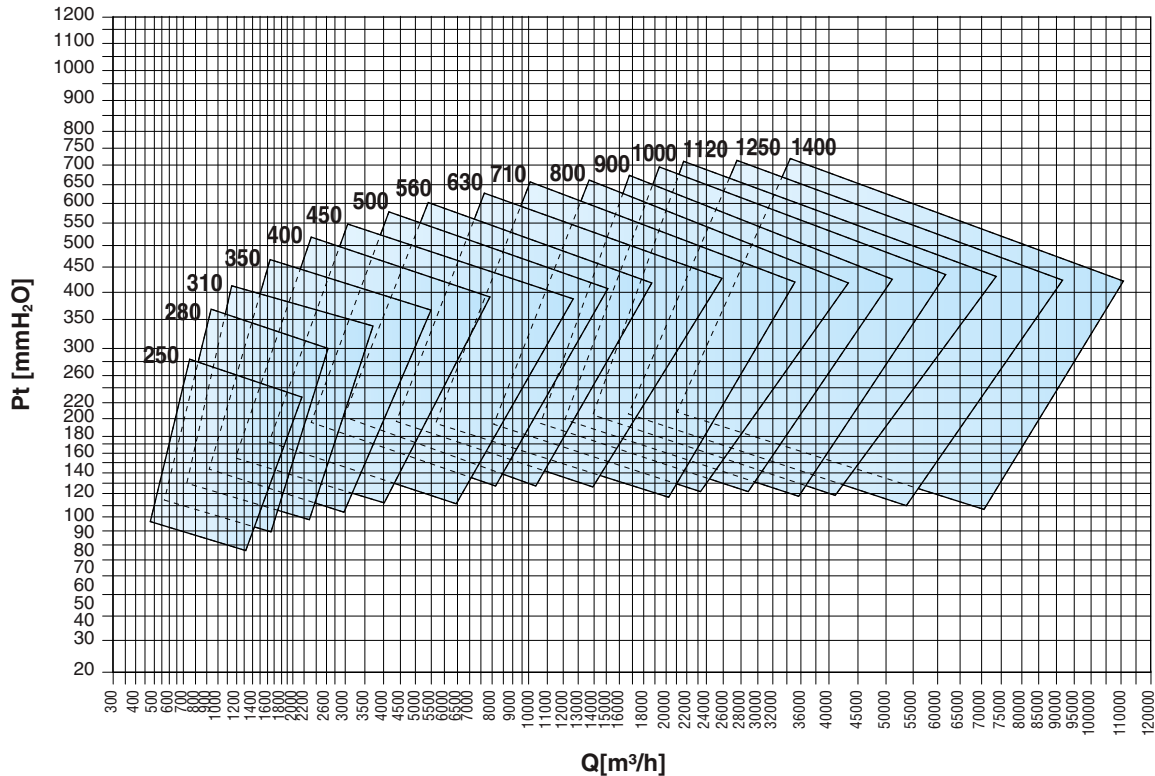

Grandezza ventilatore Fan size	RPM MAX			
	Classe I	Classe II	Classe III	Classe IV
PR-F INOX 250	5000			
PR-F INOX 280	4750			
PR-F INOX 310	4500			
PR-F INOX 350	4250			
PR-F INOX 400	4000	5600		
PR-F INOX 450 R	3750	5400		
PR-F INOX 450	3600	5000		
PR-F INOX 500 R	3500	4750		
PR-F INOX 500	3400	4500	5000	
PR-F INOX 560 R	3300	4250	4750	
PR-F INOX 560	3200	4000	4500	
PR-F INOX 630 R	3100	3750	4250	
PR-F INOX 630	2960	3600	4000	
PR-F INOX 710 R	2800	3400	3750	
PR-F INOX 710	2600	3200	3550	
PR-F INOX 800 R	2500	3000	3350	3570
PR-F INOX 800	2350	2800	3150	3500
PR-F INOX 900 R	2200	2650	3000	3300
PR-F INOX 900	2100	2500	2800	3100
PR-F INOX 1000 R	2000	2350	2700	
PR-F INOX 1000	1900	2250	2550	
PR-F INOX 1120 R	1800	2150	2400	
PR-F INOX 1120	1700	2000	2250	
PR-F INOX 1250 R	1600	1900	2100	
PR-F INOX 1250	1500	1800	2000	
PR-F INOX 1400 R	1400	1700	1900	
PR-F INOX 1400	1300	1600	1800	

VALORI RPM VALIDI FINO A 60°C RPM VALUES VALID UP TO 60°C

Fra Between	E And	Declassare velocità Degrade speed
60°C	100°C	4%
100°C	150°C	10%
150°C	200°C	16%
200°C	250°C	23%
250°C	300°C	30%
300°C	350°C	37%
350°C	400°C	45%
400°C	450°C	54%
450°C	500°C	64%

PRESTAZIONI | PERFORMANCE

PR-F INOX

Le curve prestazionali rappresentate nel presente catalogo sono state ricavate eseguendo prove sui ventilatori in accordo alla normativa ISO 5801 "Metodi di prova e condizioni di accettazione" (che sostituisce la ISO 10531:1995 ed è in accordo con la UNI EN ISO 5801:2009). Per eseguire le prove i ventilatori sono stati installati secondo quanto previsto per la categoria B: con bocca d'aspirazione libera e bocca premente collegata al banco prova. L'efficienza dei ventilatori è conforme all'obiettivo del regolamento (UE) N.327/2011, come richiesto dalla Direttiva 2009/125/CE.

The performance curves given in this catalogue were calculated by performing tests on fans in compliance with ISO 5801 "Test methods and terms of acceptance" [which replaces UNI 10531:1995 and complies with UNI EN ISO 5801:2009]. To carry out the tests the fans were installed in compliance with the requirements for category B: with free inlet and outlet connected to the test station. The fan efficiency conforms to the objective of Regulation (EU) N.327/2011, as required by Directive 2009/125/EC.

LW

La determinazione del livello di potenza sonora è stata condotta secondo la norma UNI EN ISO 3746: 1997 (Metodo di controllo con una superficie avvolgente su un piano riflettente). Alle misure sono state applicate correzioni in funzione del rumore di fondo e del riverbero ambientale. Measurement of the sound power level was carried out in compliance with UNI EN ISO 3746: 1997 (Survey method using an enveloping measurement surface over a reflecting plane). The measurements were subjected to corrections to take account of background noise and ambient reverberation levels.

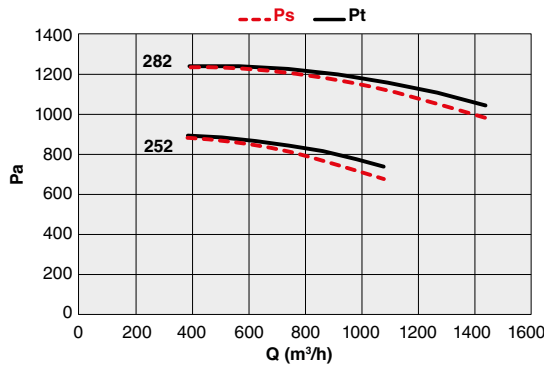

PR-F INOX 250-280

Code	Tipo Type	Modello Model	U	P	Pm (kW)	In (A)	IE3	IP/CL
A RICHIESTA UPON REQUEST	PR-F INOX	252	T	2	0,37	0,95	-	55/F
		282	T	2	0,55	1,29	-	55/F

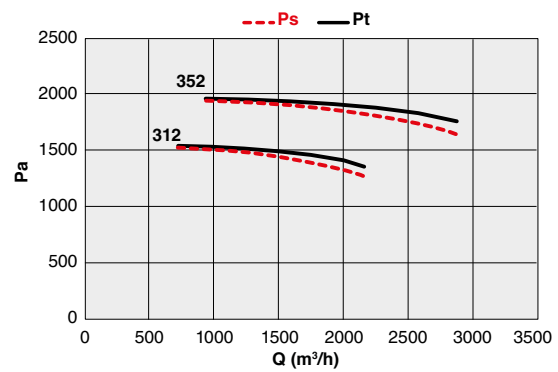

PR-F INOX 310-350

Code	Tipo Type	Modello Model	U	P	Pm (kW)	In (A)	IE3	IP/CL
A RICHIESTA UPON REQUEST	PR-F INOX	312	T	2	1,1	2,30	✓	55/F
		352	T	2	2,2	4,00	✓	55/F

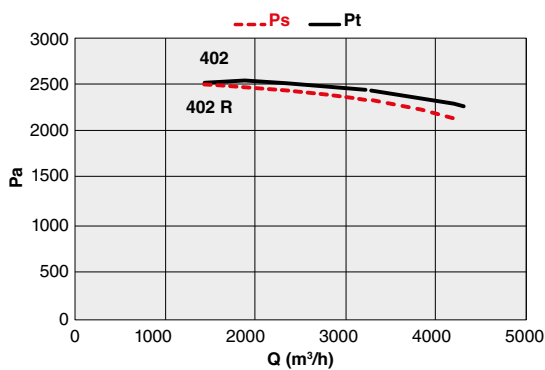

PR-F INOX 400

Code	Tipo Type	Modello Model	U	P	Pm (kW)	In (A)	IE3	IP/CL
A RICHIESTA UPON REQUEST	PR-F INOX	402 R	T	2	3	5,40	✓	55/F
		402	T	2	4	7,10	✓	55/F

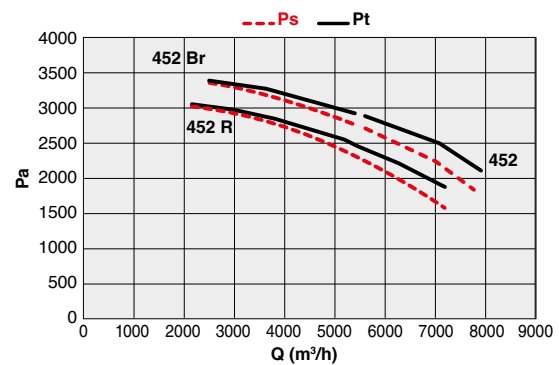

PR-F INOX 450

Code	Tipo Type	Modello Model	U	P	Pm (kW)	In (A)	IE3	IP/CL
A RICHIESTA UPON REQUEST	PR-F INOX	452 R	T	2	5,5	9,70	✓	55/F
		452 Br	T	2	5,5	9,70	✓	55/F
		452	T	2	7,5	13,10	✓	55/F

PR-F INOX 500

Code	Tipo Type	Modello Model	U	P	Pm (kW)	In (A)	IE3	IP/CL
A RICHIESTA UPON REQUEST	PR-F INOX	502 R	T	2	7,5	13,10	✓	55/F
		502 Br	T	2	9,2	18,70	✓	55/F
		502	T	2	11	20,60	✓	55/F
		504	T	4	1,1	2,50	✓	55/F

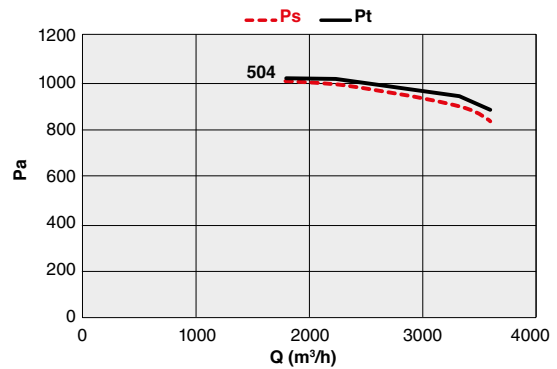
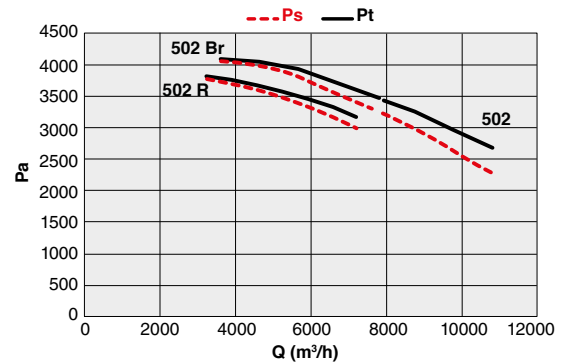

PR-F INOX 560

Code	Tipo Type	Modello Model	U	P	Pm (kW)	In (A)	IE3	IP/CL
A RICHIESTA UPON REQUEST	PR-F INOX	562 R	T	2	15	25,40	✓	55/F
		562 Br	T	2	15	25,40	✓	55/F
		562	T	2	18,5	30,80	✓	55/F
		564	T	4	2,2	4,60	✓	55/F

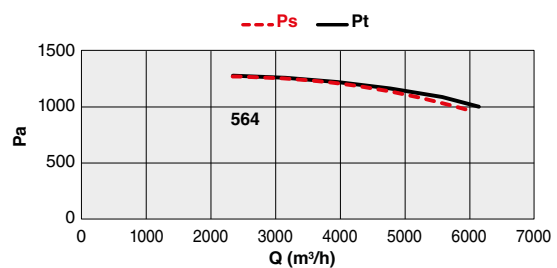
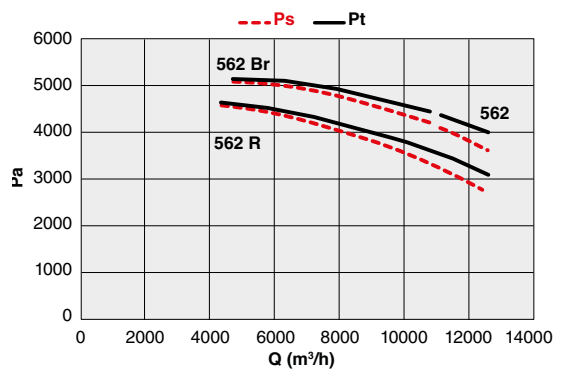

PR-F INOX 630

Code	Tipo Type	Modello Model	U	P	Pm (kW)	In (A)	IE3	IP/CL
A RICHIESTA UPON REQUEST	PR-F INOX	632 R	T	2	22	37,40	✓	55/F
		632 B	T	2	30	51,00	✓	55/F
		632Br	T	2	30	51,00	✓	55/F
		632	T	2	37	61,90	✓	55/F
		634	T	4	4	8,60	✓	55/F

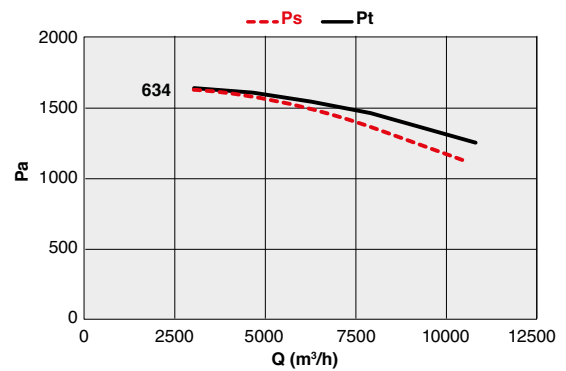
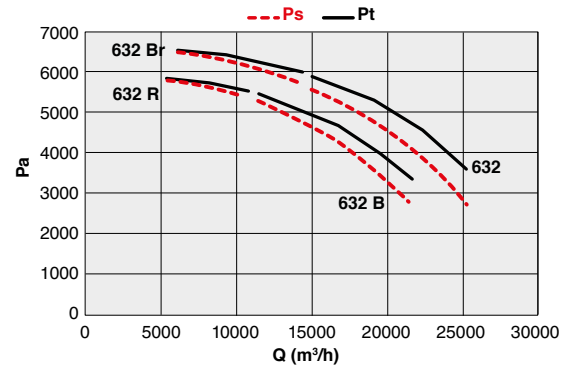

PR-F INOX 710

Code	Tipo Type	Modello Model	U	P	Pm (kW)	In (A)	IE3	IP/CL
A RICHIESTA UPON REQUEST	PR-F INOX	712 R	T	2	45	76,80	✓	55/F
		712 B	T	2	55	93,60	✓	55/F
		712 Br	T	2	55	93,60	✓	55/F
		712	T	2	75	127,00	✓	55/F
		714 R	T	4	5,5	11,00	✓	55/F
		714	T	4	7,5	15,60	✓	55/F

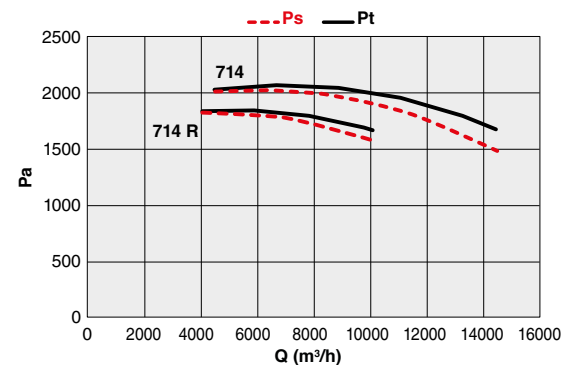
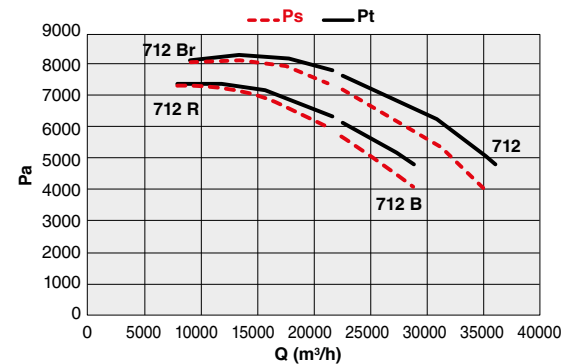

PR-F INOX 800

Code	Tipo Type	Modello Model	U	P	Pm (kW)	In (A)	IE3	IP/CL
A RICHIESTA UPON REQUEST	PR-F INOX	802 R	T	2	90	151,00	✓	55/F
		802	T	2	110	189,00	✓	55/F
		804 R	T	4	11	20,40	✓	55/F
		804	T	4	15	27,80	✓	55/F
		806	T	6	4	9,10	✓	55/F

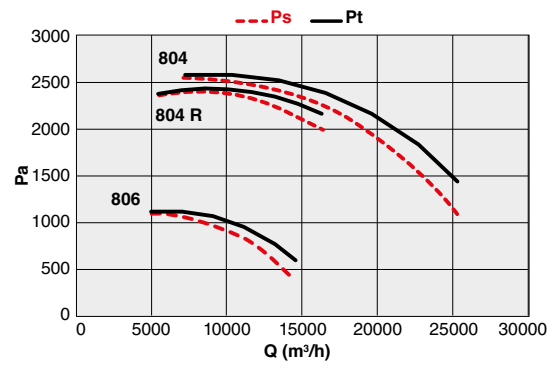
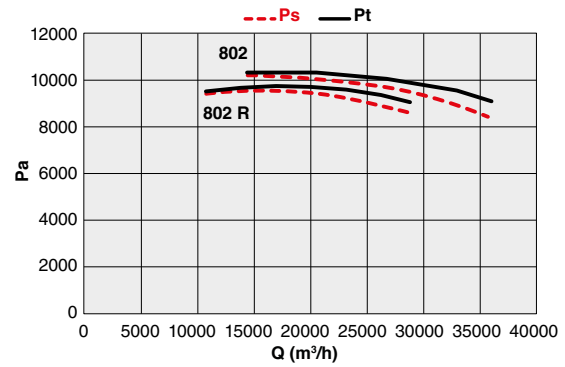

PR-F INOX 900

Code	Tipo Type	Modello Model	U	P	Pm (kW)	In (A)	IE3	IP/CL
A RICHIESTA UPON REQUEST	PR-F INOX	904 R	T	4	18,5	34,90	✓	55/F
		904 Br	T	4	22	41,50	✓	55/F
		904	T	4	30	54,60	✓	55/F
		906	T	6	7,5	15,20	✓	55/F

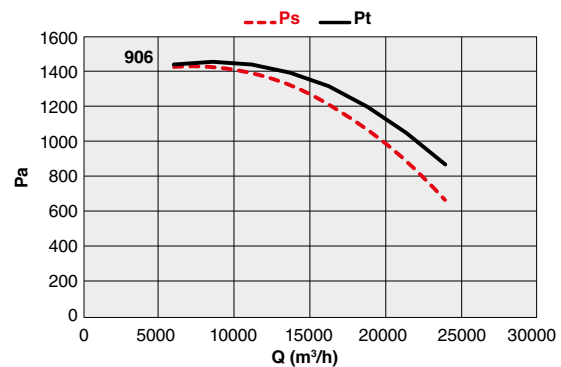
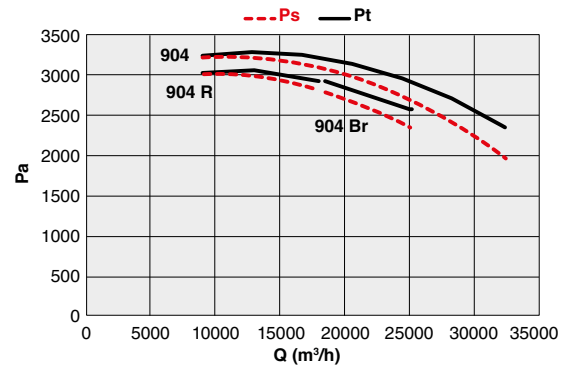

PR-F INOX 1000

Code	Tipo Type	Modello Model	U	P	Pm (kW)	In (A)	IE3	IP/CL
		1004 R	T	4	37	65,40	✓	55/F
A RICHIESTA UPON REQUEST	PR-F INOX	1004	T	4	45	80,20	✓	55/F
		1006 R	T	6	11	23,50	✓	55/F
		1006	T	6	15	30,40	✓	55/F

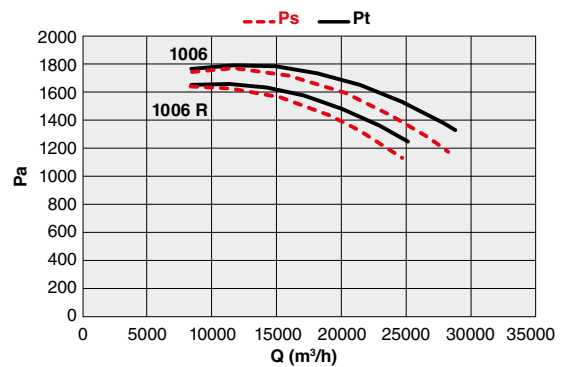
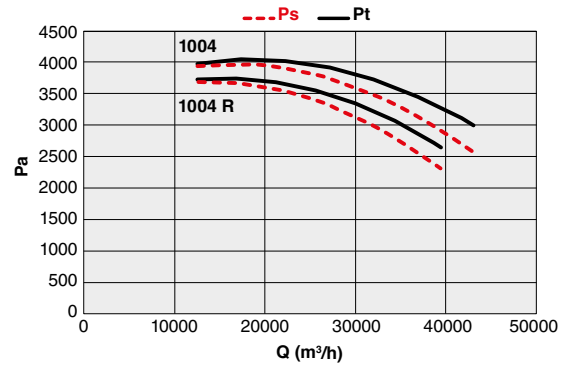

PR-F INOX 1100

Code	Tipo Type	Modello Model	U	P	Pm (kW)	In (A)	IE3	IP/CL
		1124 R	T	4	55	97,80	✓	55/F
A RICHIESTA UPON REQUEST	PR-F INOX	1124	T	4	75	138,00	✓	55/F
		1126 R	T	6	18,5	37,30	✓	55/F
		1126	T	6	22	43,00	✓	55/F

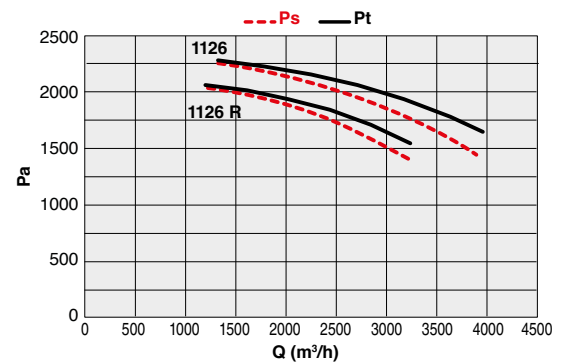
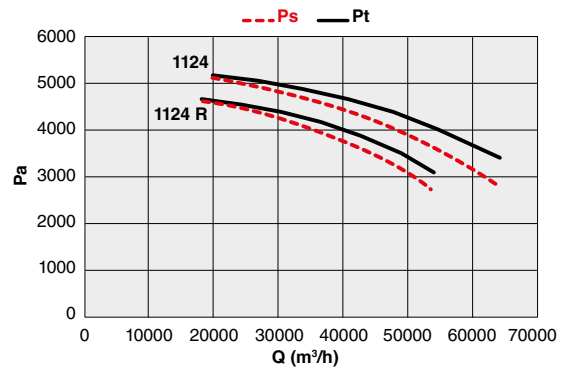

PR-F INOX 1200

Code	Tipo Type	Modello Model	U	P	Pm (kW)	In (A)	IE3	IP/CL
A RICHIESTA UPON REQUEST	PR-F INOX	1254 R	T	4	110	194,00	✓	55/F
		1254	T	4	132	234,00	✓	55/F
		1256 R	T	6	30	56,80	✓	55/F
		1256	T	6	37	68,00	✓	55/F

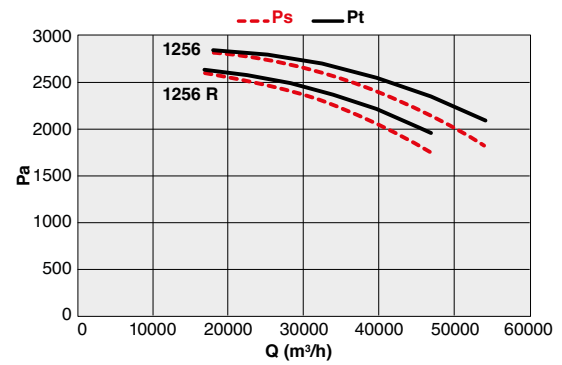
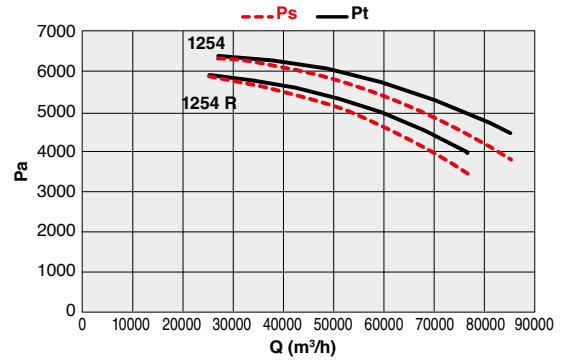

PR-F INOX 1400

Code	Tipo Type	Modello Model	U	P	Pm (kW)	In (A)	IE3	IP/CL
A RICHIESTA UPON REQUEST	PR-F INOX	1404 R	T	4	200	345,00	✓	55/F
		1404	T	4	250	433,00	✓	55/F
		1406 R	T	6	45	85,50	✓	55/F
		1406	T	6	75	138,00	✓	55/F

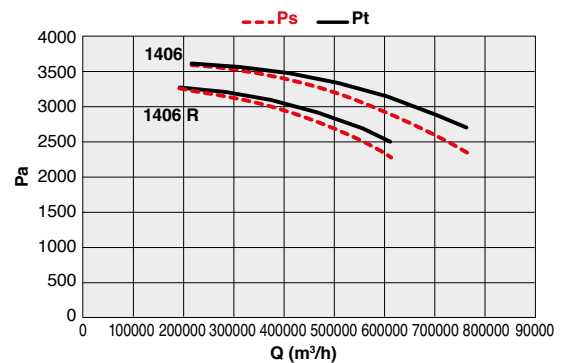
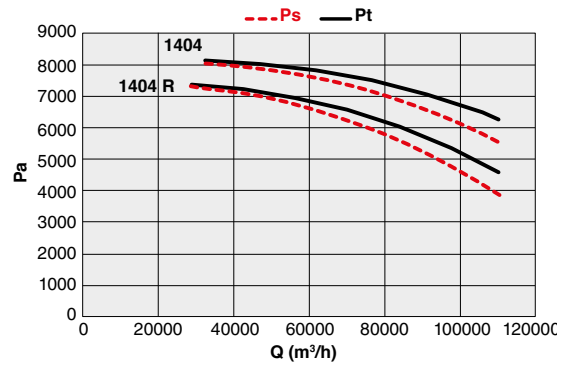

ESECUZIONE 4 ARRANGEMENT 4

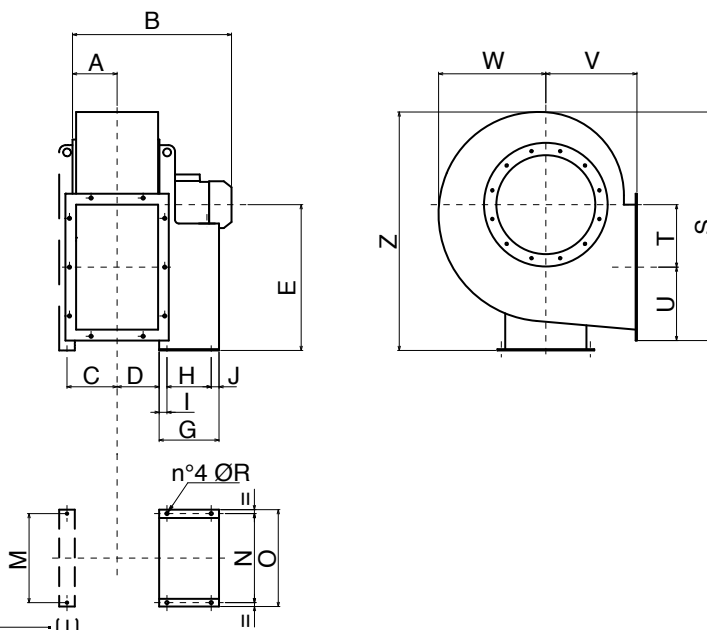

PR-F INOX 250-500

TIPO TYPE	A	B	C	D	E	G	H	I	J	M	N	O	ØR	Z	S	T	U	V	W
PR-F INOX 252	86	396	92	77	315	195	121	48	26	280	203	225	10	527	525	175	139	195	276
PR-F INOX 282	95	414	103	86	375	195	121	48	26	315	203	225	10	606	583	202	151	200	305
PR-F INOX 312	105	458	103	96	400	217	121	48	48	350	203	225	10	656	649	229	164	225	332
PR-F INOX 352	115	530	128	106	450	251	133	58	60	395	234	260	10	738	725	253	184	255	375
PR-F INOX 402 R	127	580	145	118	500	283	197	34	52	445	289	324	12	811	798	286	201	285	400
PR-F INOX 402	127	580	145	118	500	283	197	34	52	445	289	324	12	811	798	286	201	285	400
PR-F INOX 452 R	141	673	158	132	560	345	237	44	64	495	337	372	12	914	895	321	221	320	445
PR-F INOX 452 Br	141	673	158	132	560	345	237	44	64	495	337	372	12	914	895	321	221	320	445
PR-F INOX 452	141	673	158	132	560	345	237	44	64	495	337	372	12	914	895	321	221	320	445
PR-F INOX 502 R	157	705	174	148	600	345	237	44	64	545	337	372	12	1000	997	355	242	360	502
PR-F INOX 502 Br	157	705	174	148	600	345	237	44	64	545	337	372	12	1000	997	355	242	360	502
PR-F INOX 502	157	810	174	148	600	446	337	55	54	545	395	440	12	1000	997	355	242	360	502
PR-F INOX 504	157	613	174	148	600	251	133	58	60	545	234	260	12	1000	997	355	242	360	502

ESECUZIONE 4 ARRANGEMENT 4

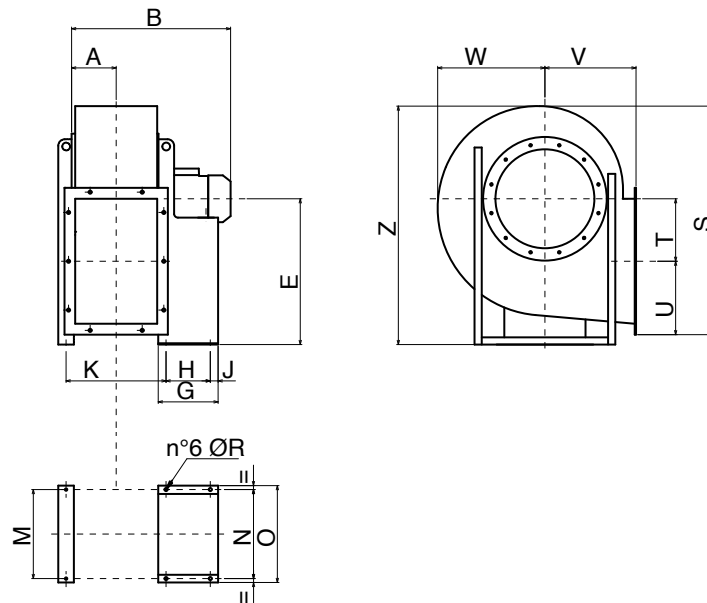

PR-F INOX 560-1400

TIPO TYPE	A	B	E	G	H	J	K	N	O	ØR	M	Z	S	T	U	V	W
PR-F INOX 562 R	180	857	670	446	337	54	406	395	440	14	632	1154	1141	390	267	400	570
PR-F INOX 562 Br	180	857	670	446	337	54	406	395	440	14	632	1154	1141	390	267	400	570
PR-F INOX 562	180	857	670	446	337	54	406	395	440	14	632	1154	1141	390	267	400	570
PR-F INOX 564	180	691	670	281	197	54	386	289	324	12	632	1154	1141	390	267	400	570
PR-F INOX 632 R	200	1021	750	465	357	38	466	434	488	18	702	1299	1282	439	294	450	630
PR-F INOX 632 Br	200	1086	750	509	381	48	475	434	568	20	702	1299	1282	439	294	450	630
PR-F INOX 632	200	1086	750	509	381	48	475	506	568	20	702	1299	1282	439	294	450	630
PR-F INOX 632 B	200	1086	750	509	381	48	475	506	568	20	702	1299	1282	439	294	450	630
PR-F INOX 634	200	752	750	285	197	54	425	289	324	12	702	1299	1282	439	294	450	630
PR-F INOX 712 R	221	1173	850	540	441	39	497	772	826	20	772	1414	1399	500	335	500	690
PR-F INOX 712 Br	221	1281	850	600	501	39	497	772	826	20	772	1414	1399	500	335	500	690
PR-F INOX 712	221	1173	850	540	441	39	497	772	826	20	772	1414	1399	500	335	500	690
PR-F INOX 712 B	221	1284	850	690	591	39	497	772	826	20	772	1414	1399	500	335	500	690
PR-F INOX 714 R	221	837	850	336	201	75	497	772	826	20	772	1414	1399	500	335	500	690
PR-F INOX 714	221	837	850	336	201	75	497	772	826	20	772	1414	1399	500	335	500	690
PR-F INOX 802 R	246	1353	950	690	591	39	546	862	926	20	862	1591	1570	560	369	560	782
PR-F INOX 802	246	1565	950	800	675	65	546	862	926	20	862	1591	1570	560	369	560	782
PR-F INOX 804 R	246	1011	950	436	315	60	546	862	926	20	862	1591	1570	560	369	560	782
PR-F INOX 804	246	1011	950	436	315	60	546	862	926	20	862	1591	1570	560	369	560	782
PR-F INOX 806	246	906	950	336	201	75	546	862	926	20	862	1591	1570	560	369	560	782
PR-F INOX 904 R	277	1146	1060	460	361	39	600	962	1026	20	962	1780	1758	630	408	630	870
PR-F INOX 904 Br	277	1146	1060	460	361	39	600	962	1026	20	962	1780	1758	630	408	630	870
PR-F INOX 904	277	1254	1060	500	401	39	600	962	1026	20	962	1780	1758	630	408	630	870
PR-F INOX 906	277	1065	1060	436	316	60	600	962	1026	20	962	1780	1758	630	408	630	870
PR-F INOX 1004 R	308	1318	1180	540	440	45	657	1056	1128	20	1056	1993	1984	710	461	710	976
PR-F INOX 1004	308	1378	1180	540	440	45	657	1056	1128	20	1056	1993	1984	710	461	710	976
PR-F INOX 1006 R	308	1147	1180	436	315	66	657	1056	1128	20	1056	1993	1984	710	461	710	976
PR-F INOX 1006	308	1279	1180	460	360	45	657	1056	1128	20	1056	1993	1984	710	461	710	976
PR-F INOX 1124 R	350	1555	1320	600	475	45	763	1178	1268	24	1178	2252	2241	800	509	800	1084
PR-F INOX 1124	350	1558	1320	690	565	45	763	1178	1268	24	1178	2252	2241	800	509	800	1084
PR-F INOX 1126 R	350	1405	1320	500	375	45	763	1178	1268	24	1178	2252	2241	800	509	800	1084
PR-F INOX 1126	350	1405	1320	500	375	45	763	1178	1268	24	1178	2252	2241	800	509	800	1084
PR-F INOX 1254 R	388	1847	1500	800	675	45	840	1310	1400	24	1310	2547	2511	900	564	900	1214
PR-F INOX 1254	388	1847	1500	800	675	45	840	1310	1400	24	1310	2547	2511	900	564	900	1214
PR-F INOX 1256 R	388	1524	1500	540	415	45	840	1310	1400	24	1310	2547	2511	900	564	900	1214
PR-F INOX 1256	388	1632	1500	600	475	45	840	1310	1400	24	1310	2547	2511	900	564	900	1214
PR-F INOX 1404 R	430	1963	1700	800	645	55	946	1450	1560	24	1450	2916	2780	1000	564	1000	1325
PR-F INOX 1404	430	1963	1700	800	645	55	946	1450	1560	24	1450	2916	2780	1000	564	1000	1325
PR-F INOX 1406 R	430	1751	1700	690	535	55	946	1450	1560	24	1450	2916	2780	1000	564	1000	1325
PR-F INOX 1406	430	1963	1700	800	645	55	946	1450	1560	24	1450	2916	2780	1000	564	1000	1325

ESECUZIONE 1 ARRANGEMENT 1

Supporto anteriore
opzionale fino al
modello 500
The front support
is optional up to
model 500

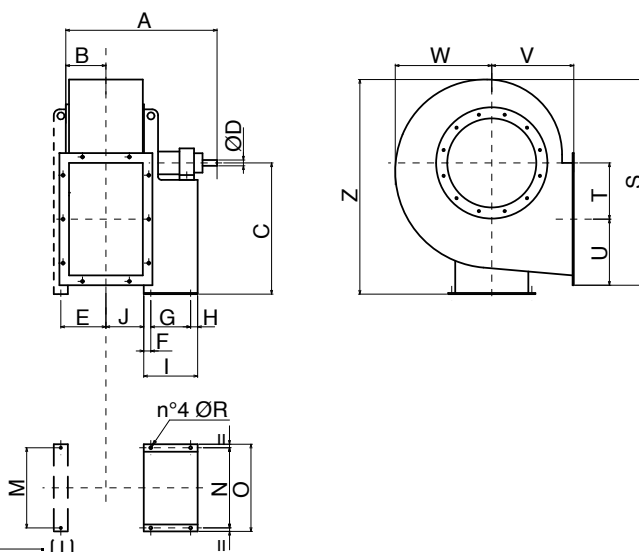

PR-F INOX 250-500

TIPO TYPE	A	B	C	ØD	E	F	G	H	I	J	M	N	O	ØR	S	T	U	V	W	Z
PR-F INOX 250	513	86	315	19	92	55	210	17	282	77	280	228	255	10	525	175	139	195	276	527
PR-F INOX 280	616	95	375	24	103	40	284	23	347	86	315	288	324	12	583	202	151	200	305	606
PR-F INOX 310	635	105	400	24	103	40	284	23	347	96	350	288	324	12	649	229	164	225	332	656
PR-F INOX 350	806	115	450	28	128	50	407	28	485	106	395	355	400	14	725	253	184	255	375	738
PR-F INOX 400	851	127	500	38	145	50	407	28	485	118	445	355	400	14	798	286	201	285	400	811
PR-F INOX 450	870	141	560	38	158	50	407	28	485	132	495	355	400	14	895	321	221	320	445	914
PR-F INOX 500	1011	157	600	42	174	50	477	33	560	148	545	364	418	17	997	355	242	360	502	1000

ESECUZIONE 1 ARRANGEMENT 1

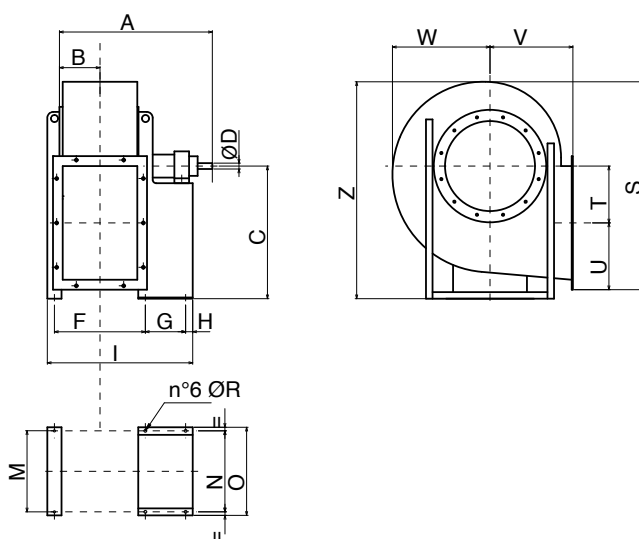

PR-F INOX 560-1600

TIPO TYPE	A	B	C	ØD	F	G	H	I	M	N	O	ØR	S	T	U	V	W	Z
PR-F INOX 560	1058	180	670	48	410	477	33	943	632	632	692	17	1141	390	267	400	570	1155
PR-F INOX 630	1102	200	750	48	450	477	33	983	702	702	762	17	1282	439	294	450	630	1300
PR-F INOX 710	1241	221	670	48	497	551	39	1114	772	772	826	19	1399	500	335	500	690	1415
PR-F INOX 800	1306	246	755	55	546	551	39	1183	862	862	926	19	1570	560	369	560	782	1591
PR-F INOX 900	1360	277	850	55	600	551	39	1237	962	962	1026	19	1758	630	408	630	870	1781
PR-F INOX 1000	1565	308	950	65	657	607	45	1376	1056	1056	1128	19	1984	710	461	710	976	1994
PR-F INOX 1120	1780	350	1060	75	763	760	45	1623	1178	1178	1268	24	2241	800	509	800	1084	2252
PR-F INOX 1250	1855	388	1190	75	840	760	45	1700	1310	1310	1400	24	2511	900	564	900	1214	2548
PR-F INOX 1400	2050	430	1320	80	946	780	55	1866	1450	1450	1560	24	2780	1000	635	1000	1325	2845
PR-F INOX 1600	2378	604	1500	90	1073	917	65	2130	1640	1640	1760	28	3099	1120	704	1120	1500	3176

BOCCA ASPIRANTE | INTEL CONE

TIPO TYPE	ØR	ØS	ØT	n° F	Ø G
PR-F INOX 250	205	241	275	8	8
PR-F INOX 280	228	265	298	8	8
PR-F INOX 310	255	292	325	8	10
PR-F INOX 350	285	332	365	8	12
PR-F INOX 400	320	366	400	8	12
PR-F INOX 450	360	405	440	8	12
PR-F INOX 500	405	448	485	12	12
PR-F INOX 560	455	497	535	12	12
PR-F INOX 630	505	551	585	12	14
PR-F INOX 710	565	629	665	12	14
PR-F INOX 800	635	698	735	12	14
PR-F INOX 900	715	775	815	16	14
PR-F INOX 1000	805	861	905	16	14
PR-F INOX 1120	905	958	1005	16	14
PR-F INOX 1250	1007	1067	1107	24	14
PR-F INOX 1400	1130	1200	1250	24	14
PR-F INOX 1600	1260	1337	1380	24	17

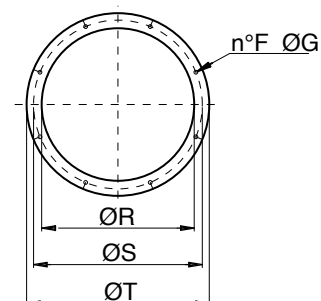

BOCCA PREMENTE | OUTLET CONE

TIPO TYPE	A	B	a1	b1	a2	b2	N1 x p	N2 x p	n° D	Ø E
PR-F INOX 250	207	148	241	182	277	218	1 x 112	1 x 112	8	12
PR-F INOX 280	231	166	265	200	301	236	1 x 112	1 x 112	8	12
PR-F INOX 310	258	185	292	219	328	255	1 x 112	2 x 112	10	12
PR-F INOX 350	288	205	332	249	368	285	1 x 125	2 x 125	10	12
PR-F INOX 400	322	229	366	273	402	309	1 x 125	2 x 125	10	12
PR-F INOX 450	361	256	405	300	441	336	1 x 125	2 x 125	10	12
PR-F INOX 500	404	288	448	332	484	368	2 x 125	3 x 125	14	12
PR-F INOX 560	453	322	497	366	533	402	2 x 125	3 x 125	14	12
PR-F INOX 630	507	361	551	405	587	441	2 x 125	3 x 125	14	12
PR-F INOX 710	569	404	629	464	669	504	2 x 160	3 x 160	14	14
PR-F INOX 800	638	453	698	513	738	553	2 x 160	3 x 160	14	14
PR-F INOX 900	715	507	775	567	815	607	2 x 160	4 x 160	16	14
PR-F INOX 1000	801	569	871	639	921	689	2 x 200	3 x 200	14	14
PR-F INOX 1120	898	638	968	708	1018	758	3 x 200	4 x 200	18	14
PR-F INOX 1250	1007	715	1077	785	1127	835	3 x 200	4 x 200	18	14
PR-F INOX 1400	1130	801	1210	881	1270	941	3 x 200	5 x 200	20	18
PR-F INOX 1600	1267	898	1347	978	1407	1038	4 x 200	6 x 200	24	18

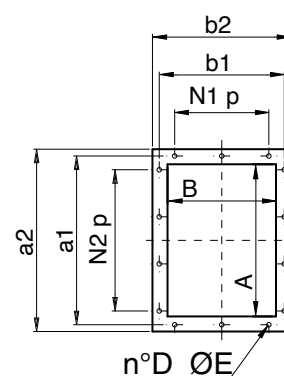

DIMENSIONI E ORIENTAMENTI mm

PR-F INOX

DIMENSIONS AND DISCHARGE ANGLES

Dimensioni dei modelli secondo l'orientamento.

Dimensions of models according to the discharge angle.

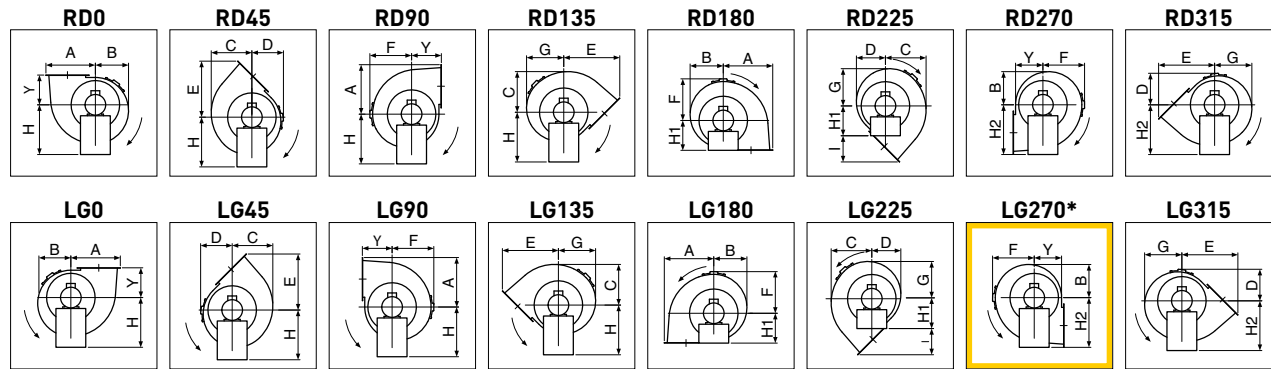

* Versione standard | Standard version.

TIPO TYPE	A	B	C	D	E	F	G	I	Y	H	H1	H2
PR-F INOX 250	314	212	255	215	360	276	235	165	195	315	195	315
PR-F INOX 280	353	231	287	226	391	305	262	191	200	375	200	375
PR-F INOX 310	393	256	316	253	437	332	288	212	225	400	225	400
PR-F INOX 350	437	288	359	278	489	375	325	234	255	450	255	450
PR-F INOX 400	487	311	387	306	546	400	353	261	285	500	285	500
PR-F INOX 450	542	354	435	342	609	445	398	289	320	560	320	560
PR-F INOX 500	597	400	490	380	677	502	450	317	360	600	360	600
PR-F INOX 560	657	485	555	425	747	570	542	347	400	670	400	670
PR-F INOX 630	733	550	619	476	836	630	603	386	450	750	450	750
PR-F INOX 710	835	565	719	497	944	690	662	444	500	670	500	850
PR-F INOX 800	929	641	811	562	1053	782	749	493	560	755	560	950
PR-F INOX 900	1038	721	905	633	1180	870	835	550	630	850	630	1060
PR-F INOX 1000	1171	814	1015	718	1330	976	936	620	710	950	710	1180
PR-F INOX 1120	1309	932	1133	793	1491	1084	1037	691	800	1060	800	1320
PR-F INOX 1250	1464	1048	1270	898	1671	1214	1163	771	900	1190	900	1500
PR-F INOX 1400	1635	1145	1395	990	1863	1325	1272	863	1000	1320	1000	1700
PR-F INOX 1600	1824	1276	1572	1085	2081	1500	1434	961	1120	1500	1120	1900

PESI | WEIGHTS

Modello Model	Kg*
PR-F INOX 252	28
PR-F INOX 282	30
PR-F INOX 312	42
PR-F INOX 352	62
PR-F INOX 402 R	82
PR-F INOX 402	82
PR-F INOX 452 R	106
PR-F INOX 452 Br	107
PR-F INOX 452	107
PR-F INOX 502 R	141
PR-F INOX 502 Br	149
PR-F INOX 502	175
PR-F INOX 504	100
PR-F INOX 562 R	217

Modello Model	Kg*
PR-F INOX 562 Br	218
PR-F INOX 562	228
PR-F INOX 564	143
PR-F INOX 632 R	375
PR-F INOX 632 Br	438
PR-F INOX 632	443
PR-F INOX 632 B	443
PR-F INOX 634	190
PR-F INOX 712 R	540
PR-F INOX 712 Br	625
PR-F INOX 712	540
PR-F INOX 712 B	760
PR-F INOX 714 R	275
PR-F INOX 714	288

Modello Model	Kg*
PR-F INOX 802 R	904
PR-F INOX 802	1046
PR-F INOX 804 R	418
PR-F INOX 804	432
PR-F INOX 806	390
PR-F INOX 904 R	590
PR-F INOX 904 Br	605
PR-F INOX 904	687
PR-F INOX 906	504
PR-F INOX 1004 R	933
PR-F INOX 1004	975
PR-F INOX 1006 R	684
PR-F INOX 1006	759
PR-F INOX 1124 R	1210

Modello Model	Kg*
PR-F INOX 1124	1390
PR-F INOX 1126 R	935
PR-F INOX 1126	956
PR-F INOX 1254 R	1860
PR-F INOX 1254	2055
PR-F INOX 1256 R	1283
PR-F INOX 1256	1378
PR-F INOX 1404 R	2766
PR-F INOX 1404	2766
PR-F INOX 1406 R	2150
PR-F INOX 1406	2356

* Pesi indicativi | Indicative weights



LATO ASPIRANTE | INLET SIDE

Flangia - Rete - Giunto | Flange - Guard - Flexible connector

Flangia Flange	Rete Guard	Giunto Connector	Tipo Type	ØR	ØS	ØT	F	ØG	L
5B01328	5RE1017	5SU1405	250	205	241	275	8	8	145
5B01327	5RE1018	5SU3137	280	228	265	298	8	8	145
5B01323	5RE4050	5SU1096	310	255	292	325	8	10	145
5B01364	5RE1027	5SU3147	350	285	332	365	8	12	145
5B01334	5RE1002	5SU3101	400	320	366	400	8	12	145
5B01330	5RE1022	5SU3500	450	360	405	440	8	12	145
5B01347	5RE5606	5SU1102	500	405	448	485	12	12	145
5B08105	5RE1046	5SU1406	560	455	497	535	12	12	145
5B01380	5RE1180	5SU1180	630	505	551	585	12	14	180
5B08087	5RE1016	5SU8004	710	565	629	665	12	14	180
5B01391	5RE1013	5SU9000	800	635	698	735	12	14	180
5B08101	5RE1003	5SU1100	900	715	775	815	16	14	180
5B01357	5RE1031	5SU8000	1000	805	861	905	16	14	180
5B01359	5RE0090	5SU9002	1120	905	958	1005	16	14	230
5B01408	5RE1010	5SU1144	1250	1007	1067	1107	24	14	230
5B01398	5RE1011	5SU1145	1400	1130	1200	1250	24	14	230
5B01409	5RE1014	5SU1146	1600	1260	1337	1380	24	17	230

Dimensioni in mm | Dimensions in mm

FLANGIA | FLANGE

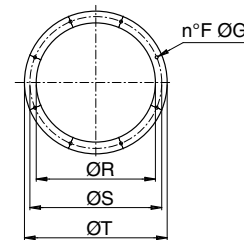

RETE | GUARD

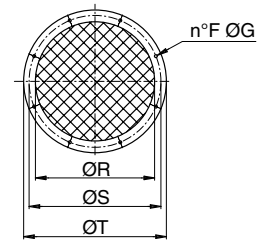

GIUNTO | FLEXIBLE CONNECTOR

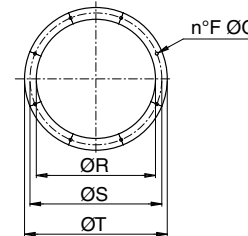

LATO PREMENTE | OUTLET SIDE

Flangia - Rete - Giunto | Flange - Guard - Flexible connector

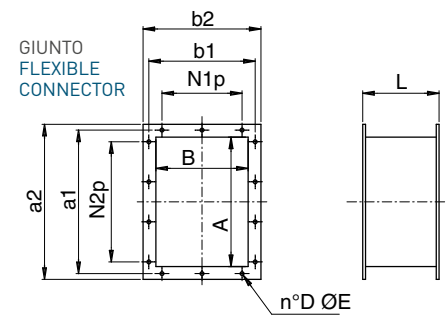
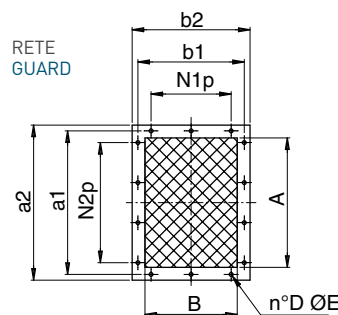
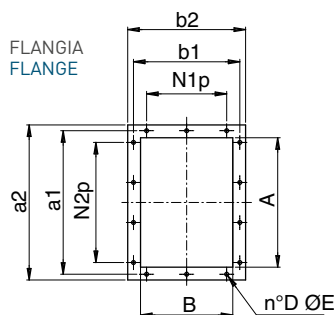

Flangia Flange	Rete Guard	Giunto Connector	Tipo Type	A	B	a1	b1	a2	b2	N1 x p	N2 x p	n° D	ØE	L
5B05019	5RE4051	5SU3143	250	207	148	241	182	277	218	1 x 112	1 x 112	8	12	145
5B01329	5RE1019	5SU1131	280	231	166	265	200	301	236	1 x 112	1 x 112	8	12	145
5B01324	5RE3138	5SU3138	310	258	185	292	219	328	255	1 x 112	2 x 112	10	12	145
5B01365	5RE1130	5SU1130	350	288	205	332	249	368	285	1 x 125	2 x 125	10	12	145
5B01362	5RE1348	5SU3148	400	322	229	366	273	402	309	1 x 125	2 x 125	10	12	145
5B01340	5RE1023	5SU3501	450	361	256	405	300	441	336	1 x 125	2 x 125	10	12	145
5B01344	5RE1020	5SU4023	500	404	288	448	332	484	368	2 x 125	3 x 125	14	12	145
5B01348	5RE1006	5SU5601	560	453	322	497	366	533	402	2 x 125	3 x 125	14	12	145
5B01381	5RE1024	5SU1181	630	507	361	551	405	587	441	2 x 125	3 x 125	14	12	145
5B08104	5RE1004	5SU4021	710	569	404	629	464	669	504	2 x 160	3 x 160	14	14	180
5B01310	5RE1035	5SU1402	800	638	453	698	513	738	553	2 x 160	3 x 160	14	14	180
5B01390	5RE1009	5SU1101	900	715	507	775	567	815	607	2 x 160	4 x 160	16	14	180
5B01392	5RE3079	5SU3079	1000	801	569	871	639	921	689	2 x 200	3 x 200	14	14	180
5B01360	5RE9003	5SU9003	1120	898	638	968	708	1018	758	3 x 200	4 x 200	18	14	180
5B08100	5RE1128	5SU1128	1250	1007	715	1077	785	1127	835	3 x 200	4 x 200	18	14	180
5B01399	5RE1399	5SU1399	1400	1130	801	1210	881	1270	941	3 x 200	5 x 200	20	18	180
5B01413	5RE1413	5SU1413	1600	1267	898	1347	978	1407	1038	4 x 200	6 x 200	24	18	180

Dimensioni in mm | Dimensions in mm