

> PV-L ATX



Ventilatori centrifughi pale rovesce per aria polverosa e alte pressioni.
Backward curved blade centrifugal fans for dusty and high pressure air.



Certificato / *Certificate:*



TUV 14 ATEX 139957
TUV 14 ATEX 139958
TUV 14 ATEX 139959



Versione speciale acciaio Inox a richiesta
Special version in stainless steel upon request.

DESCRIZIONE GENERALE

I ventilatori della serie PV-L ATX sono costruiti in conformità alle direttive ATEX 94/9/CE e 2014/34/UE e adatti per ambienti dove la presenza di gas infiammabili rende necessario garantire una corretta estrazione d'aria evitando rischi d'esplosione, in particolare negli impianti certificati ATEX categoria 3, zona 2, zona 2-22 (3G/3GD) e categoria 2, zona 1 e zona 1-21 (2G/GD) nelle rispettive costruzioni. La serie PV-L ATX è adatta ad impianti canalizzati che movimentano elevate portate d'aria e alte prevalenze come ad esempio sale batterie, industrie chimiche, petrolchimiche ecc. Il loro impiego è previsto per aria con temperatura da -20°C a +40°C.

COSTRUZIONE

- Cassa a spirale realizzata in lamiera d'acciaio e protetta contro gli agenti atmosferici con vernici a polvere epossipoliestiriche, flange di collegamento norme ISO 6580/EUROVENT 1-2.
- Boccaglio in aspirazione con ampio raggio.
- Girante a semplice aspirazione con pale curve ad alto rendimento aeraulico, realizzate in lamiera d'acciaio protetta con vernici epossipoliestiriche. Sono previste versioni per alte velocità in classe 3.
- Esecuzioni 4 direttamente accoppiate e esecuzioni 1-9-12 con supporti cuscinetti monoblocco realizzati in fusione di ghisa per un ideale allineamento degli elementi volventi e facile lubrificazione. Cinghie di trasmissione, pulegge e supporto motore idoneo per la regolazione della tensione cinghie. Carter a protezione dagli organi in movimento esterni alla voluta, conformi alla EN12499.

MOTORIZZAZIONI

- Motore asincrono trifase ATEX per atmosfere esplosive Categoria G gruppo II classe termica T4 protezione Exd costruito secondo le norme internazionali IEC 60034, IEC60072, IEC60079, e/o 61241, EMC 2004/108/CE, LVD 2006/95/CE, IP55, classe F, Forma B3 o B5, marchiati CE e certificato ATEX da ente notificato. Idoneo a servizio S1, funzionamento continuo a carico costante.

ACCESSORI

- Tappo scarico condensa (TS)
- Portella d'ispezione (PI)
- Controflangia per bocca aspirante (CFA)
- Controflangia per bocca premente (CFP)
- Rete di protezione per bocca aspirante (RA)
- Rete di protezione per bocca premente (RP)
- Giunto antivibrante per bocca aspirante (GA)
- Giunto antivibrante per bocca premente (GP)
- Regolatore di portata in aspirazione
- Serranda ad alette contrapposte in premente
- Supporti antivibranti

A RICHIESTA

- Versione realizzata con cassa e girante in lamiera acciaio inossidabile AISI 304 o AISI 316.
- Versioni con temperature di esercizio diverse.
- Versioni con motori idonei alla regolazione della velocità.
- Versioni con motori a doppia polarità.

GENERAL DESCRIPTION

The fans of the PV-L ATX series are built-in conformity to the ATEX Directives 94/9/CE and 2014/34/UE. They are suitable for installation in plants where the presence of inflammable gas makes necessary to guarantee a correct air exhaust avoiding the risk of explosion, in particular certified ATEX plants category 3, zone 2, zone 2-22 (3G/3GD) and category 2, zone 1 and zone 1-21 (2G/GD) in the respective constructions. The series PV-L ATX is suitable for duct installations which move high airflow and high pressure air such as electrical storage rooms, chemical or petrochemical industries and so on. They are suitable to convey air with temperature from -20°C to +40°C.

CONSTRUCTION

- Volute casing in steel sheet, protected against atmospheric agents by epoxy paint. Connection flanges ISO 6580/EUROVENT 1-2.
- Single inlet backward curved wheel with high efficiency, manufactured in steel sheet and epoxy painted. For high rotational speed, versions in class 3 are foreseen.
- Aerodynamically shaped inlet cone.
- Execution 4 directly coupled and executions 1-9-12 with mono-block support in cast iron with ball bearings, designed for an ideal alignment of the ball bearings and an easy lubrication. Pulleys, belts and motor support suitable for the regulation of the belts tension. Belt protection guard according to EN12499.

MOTOR

- Asynchronous three-phase ATEX for explosive atmospheres category G group II thermal class T4 protection Exd motors according to international standards IEC 60034, IEC 60072, EMC 2004/108/CE, LVD 2006/95/CE, CE marked, IP 55, Class F, B3 or B5 format and ATEX certified da Notify body. Suitable to S1 service (continuous working at constant load).

ACCESSORIES

- Condensation drain hole (TS)
- Inspection door (PI)
- Inlet counter-flange (CFA)
- Outlet counter-flange (CFP)
- Inlet protection guard (RA)
- Outlet protection guard (RP)
- Inlet flexible connector (GA)
- Outlet flexible connector (GP)
- Inlet vane control
- Outlet setting shutter
- Anti-vibration mounts

UPON REQUEST

- Version with volute and impeller in stainless steel AISI 304 or AISI 316.
- Versions with different temperatures.
- Versions with motors suitable for speed regulation.
- Versions with double polarity motors.

Per le dimensioni dei modelli secondo gli orientamenti vedere pagina 87.

The dimensions of the models according to the discharge angles are available at page 87.

Rotazione Rotation RD								
Forma-Form	0	45	90	135	180(*)	225(*)	270	315
Rotazione Rotation LG								

NB.: Orientamento standard **LG270°** / *Standard orientation **LG270°***

(*) Richiede costruzione speciale / *Request special construction*

ESECUZIONI *Executions*

PV-L ATX

- 4: Girante a sbalzo direttamente accoppiata al motore, sostenuta dalla base/sedia.
4: Impeller directly coupled to the motor supported by the motor support base.

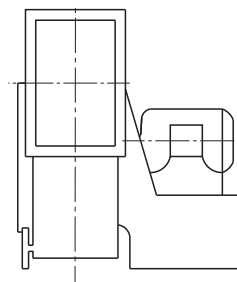

Le prestazioni aerauliche sono rilevate in conformità alla norma EN ISO 5801 e ISO 580 con densità dell'aria standard avente peso specifico 1,2 Kg/m³. Alimentazione 230V/1Ph/50Hz o 400V/3Ph/50Hz.

Air performances measured according to EN ISO 5801 and ISO 5802 standards with air density with 1.2 kg/m³ specific weight. Power supply 400V/3Ph/50Hz.

Lp: Livello di pressione sonora ottenuti attraverso letture in campo libero, al massimo rendimento, a 1,5 metri dal ventilatore. Nell'ambito della prova il ventilatore è canalizzato secondo le norme UNI 717973P.

Lp: Sound pressure levels are measured in free field at the maximum output and at a distance of 1,5 meters from the fan. During tests, the fan is ducted according to UNI 7179-73P standard.

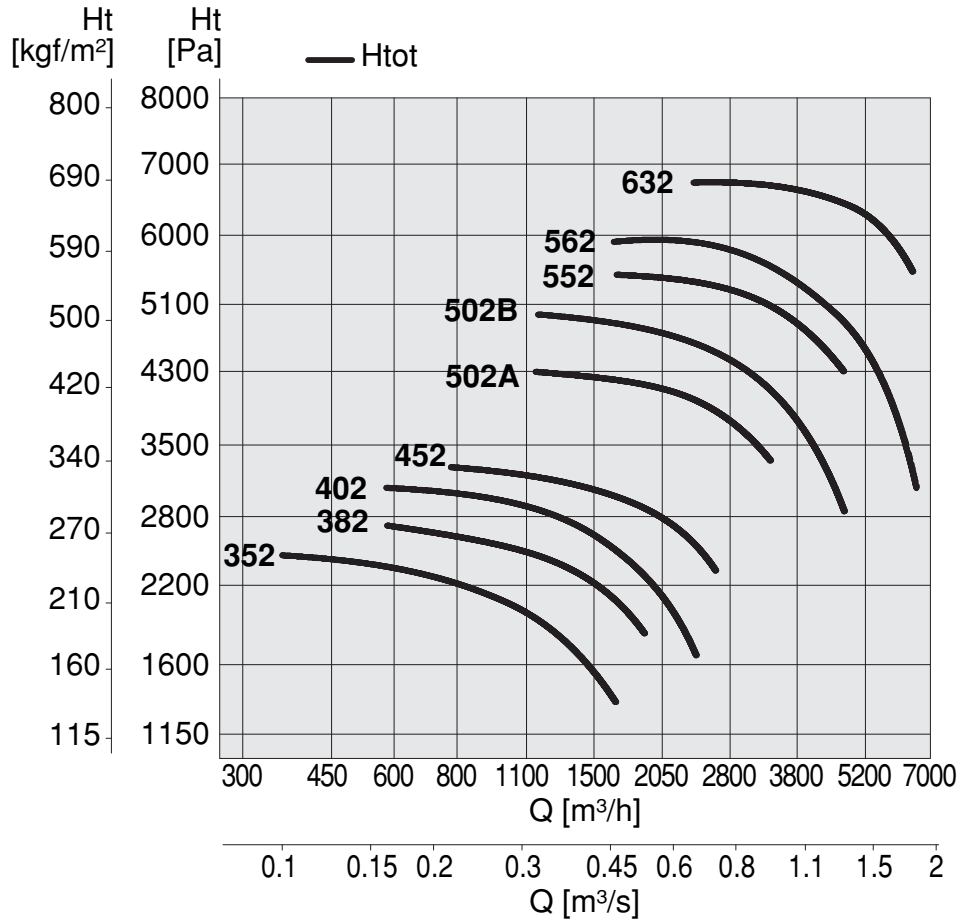

PV-L ATX 35

Tipo Type	Modello Model	U	P	Pm (kW)	In (A)	IP/CL	Lp dB(A)	Mot. (Gr)
PV-L ATX	352	T	2	1,10	2,50	55/F	63	80

Limiti d'impiego - Operational limit

Tipo Type	Modello Model	Q max (m³/h)	Pt min (mm H ₂ O)	C max (m/s)	S (m²)	Pd² (kgm²)
PV-L ATX	352	1650	138	30,60	0,015	0,34

Livelli sonori - Sound levels / dB(A)

[Hz]	62,5	125	250	500	1000	2000	4000	8000	TOT
PV-L 352 Lw	49	61	67	73	72	68	60	50	77
PV-L 352 Lp	35	47	53	59	58	54	46	36	63

PV-L ATX 38

Tipo Type	Modello Model	U	P	Pm (kW)	In (A)	IP/CL	Lp dB(A)	Mot. (Gr)
PV-L ATX	382	T	2	1,50	3,40	55/F	68	90

Limiti d'impiego - Operational limit

Tipo Type	Modello Model	Q max (m³/h)	Pt min (mm H ₂ O)	C max (m/s)	S (m²)	Pd² (kgm²)
PV-L ATX	382	1880	186	27,54	0,019	0,60

Livelli sonori - Sound levels / dB(A)

[Hz]	62,5	125	250	500	1000	2000	4000	8000	TOT
PV-L 382 Lw	54	66	72	78	77	73	65	55	82
PV-L 382 Lp	40	52	58	64	63	59	51	41	68

Le prestazioni aerauliche sono rilevate in conformità alla norma EN ISO 5801 e ISO 5802 con densità dell'aria standard avente peso specifico 1,2 Kg/m³. Alimentazione 230V/1Ph/50Hz o 400V/3Ph/50Hz.

Lp: Livello di pressione sonora ottenuti attraverso letture in campo libero, al massimo rendimento, a 1,5 metri dal ventilatore. Nell'ambito della prova il ventilatore è canalizzato secondo le norme UNI 7179/3P.

Air performances measured according to EN ISO 5801 and ISO 5802 standards with air density with 1.2 kg/m³ specific weight. Power supply 400V/3Ph/50Hz.

Lp: Sound pressure levels are measured in free field at the maximum output and at a distance of 1,5 meters from the fan. During tests, the fan is ducted according to UNI 7179-73P standard.

PV-L ATX 40

Tipo Type	Modello Model	U	P	P _m (kW)	In (A)	IP/CL	L _p dB(A)	Mot. (Gr)
PV-L ATX	402	T	2	2,20	4,90	55/F	68	90

Limiti d'impiego - Operational limit

Tipo Type	Modello Model	Q max (m ³ /h)	Pt min (mm H ₂ O)	C max (m/s)	S (m ²)	Pd ² (kgm ²)
PV-L ATX	402	2390	170	34,98	0,019	0,70

Livelli sonori - Sound levels / dB(A)

[Hz]	62,5	125	250	500	1000	2000	4000	8000	TOT
PV-L 402 Lw	54	66	72	78	77	73	65	55	82
PV-L 402 Lp	40	52	58	64	63	59	51	41	68

PV-L ATX 45

Tipo Type	Modello Model	U	P	P _m (kW)	In (A)	IP/CL	L _p dB(A)	Mot. (Gr)
PV-L ATX	452	T	2	3,00	6,40	55/F	70	100

Limiti d'impiego - Operational limit

Tipo Type	Modello Model	Q max (m ³ /h)	Pt min (mm H ₂ O)	C max (m/s)	S (m ²)	Pd ² (kgm ²)
PV-L ATX	452	2600	238	29,91	0,0242	1,00

Livelli sonori - Sound levels / dB(A)

[Hz]	62,5	125	250	500	1000	2000	4000	8000	TOT
PV-L 452 Lw	56	68	74	80	79	75	67	57	84
PV-L 452 Lp	42	54	60	66	65	61	53	43	70

PV-L ATX 50

Tipo Type	Modello Model	U	P	P _m (kW)	In (A)	IP/CL	L _p dB(A)	Mot. (Gr)
PV-L ATX	502/A	T	2	4,00	8,00	55/F	75	112
PV-L ATX	502/B	T	2	5,50	10,80	55/F	75	132

Limiti d'impiego - Operational limit

Tipo Type	Modello Model	Q max (m ³ /h)	Pt min (mm H ₂ O)	C max (m/s)	S (m ²)	Pd ² (kgm ²)
PV-L ATX	502/A	3360	340	31,14	0,03	1,30
PV-L ATX	502/B	4700	290	43,64	0,03	1,60

Livelli sonori - Sound levels / dB(A)

[Hz]	62,5	125	250	500	1000	2000	4000	8000	TOT
PV-L 502/A Lw	61	73	79	85	84	80	72	62	89
PV-L 502/A Lp	47	59	65	71	70	66	58	48	75
PV-L 502/B Lw	61	73	78	85	84	80	72	62	89
PV-L 502/B Lp	47	59	64	71	70	66	58	48	75

PV-L ATX 55

Tipo Type	Modello Model	U	P	P _m (kW)	In (A)	IP/CL	L _p dB(A)	Mot. (Gr)
PV-L ATX	552	T	2	7,5	14,10	55/F	78	132

Limiti d'impiego - Operational limit

Tipo Type	Modello Model	Q max (m ³ /h)	Pt min (mm H ₂ O)	C max (m/s)	S (m ²)	Pd ² (kgm ²)
PV-L ATX	552	4700	438	34,38	0,038	2,00

Livelli sonori - Sound levels / dB(A)

[Hz]	62,5	125	250	500	1000	2000	4000	8000	TOT
PV-L 552 Lw	64	76	82	88	87	83	75	65	92
PV-L 552 Lp	50	62	68	74	73	69	61	51	78

PV-L ATX 56

Tipo Type	Modello Model	U	P	P _m (kW)	In (A)	IP/CL	L _p dB(A)	Mot. (Gr)
PV-L ATX	562	T	2	11,00	20,60	55/F	78	160

Limiti d'impiego - Operational limit

Tipo Type	Modello Model	Q max (m ³ /h)	Pt min (mm H ₂ O)	C max (m/s)	S (m ²)	Pd ² (kgm ²)
PV-L ATX	562	6560	315	47,97	0,038	2,60

Livelli sonori - Sound levels / dB(A)

[Hz]	62,5	125	250	500	1000	2000	4000	8000	TOT
PV-L 562 Lw	64	76	82	88	87	83	75	65	92
PV-L 562 Lp	50	62	68	74	73	69	61	51	78

PV-L ATX 63

Tipo Type	Modello Model	U	P	P _m (kW)	In (A)	IP/CL	L _p dB(A)	Mot. (Gr)
PV-L ATX	632	T	2	15,00	27,50	55/F	82	160

Limiti d'impiego - Operational limit

Tipo Type	Modello Model	Q max (m ³ /h)	Pt min (mm H ₂ O)	C max (m/s)	S (m ²)	Pd ² (kgm ²)
PV-L ATX	632	6430	565	37,97	0,047	3,20

Livelli sonori - Sound levels / dB(A)

[Hz]	62,5	125	250	500	1000	2000	4000	8000	TOT
PV-L 632 Lw	68	80	86	92	91	87	79	69	96
PV-L 632 Lp	54	66	72	78	77	73	65	55	82

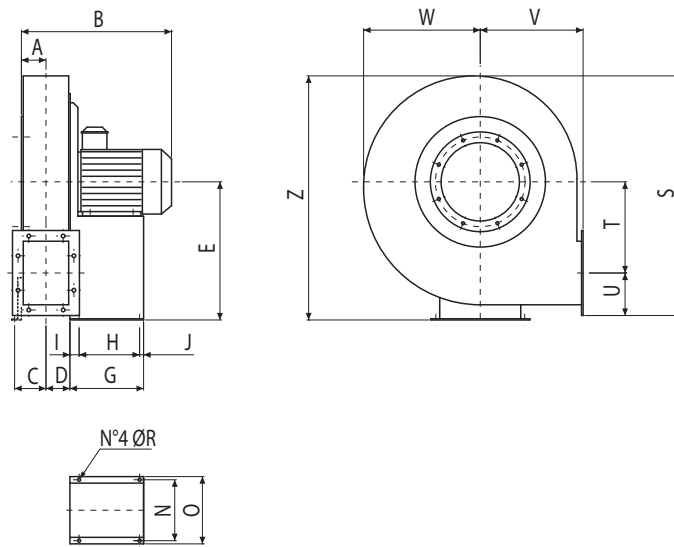

TIPO / TYPE	A	B	C	D	E	G	H	I	J	N	O	R	S	T	U	V	W	Z
PV-L ATX 352 T	65	377	70	56	355	211	121	45	45	203	225	10	585	215	108	250	315	617
PV-L ATX 382 T	71	437	76	63	375	246	133	55	58	234	260	10	585	215	108	250	340	659
PV-L ATX 402T	71	437	76	63	375	246	133	55	58	234	260	10	640	238	118	280	340	659
PV-L ATX 452T	78	503	86	70	400	276	197	30	49	289	324	12	705	265	128	300	375	713
PV-L ATX 502AT	86	520	94	78	450	276	197	30	49	289	324	12	780	297	139	335	410	795
PV-L ATX 502BT	86	560	94	78	450	336	237	40	59	336	372	12	780	297	139	335	410	795
PV-L ATX 552T	95	579	106	88	500	336	237	40	59	337	372	12	880	337	151	375	460	893
PV-L ATX 562T	95	684	106	88	500	436	337	50	49	395	440	14	880	337	151	375	460	893
PV-L ATX 632T	105	703	116	98	560	436	337	50	49	395	440	14	985	381	164	425	515	1000

Dimensioni in mm / Dimensions in mm

Dimensioni dei modelli secondo l'orientamento.
Dimensions of models according to the discharge angle.

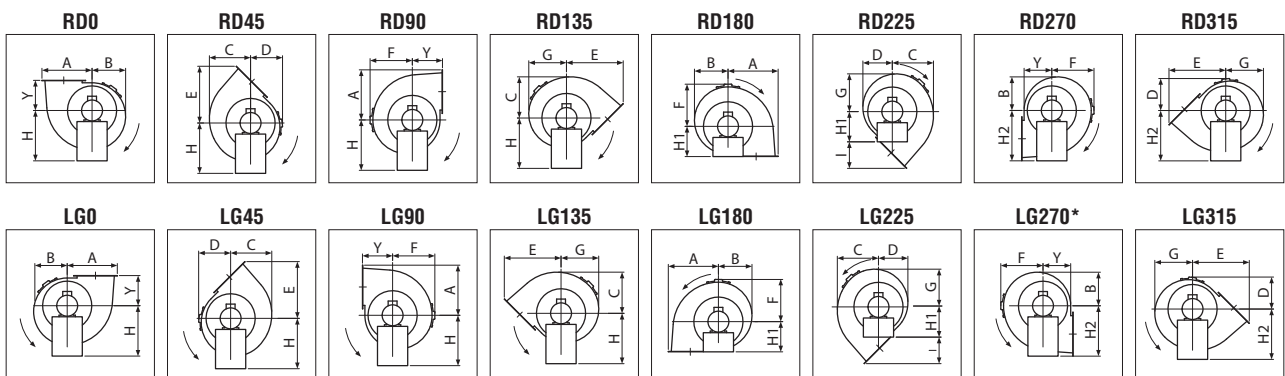

* Versione standard / Standard version.

TIPO/TYPE	A	B	C	D	E	F	G	I	Y	H	H1	H2
PV-L 35	323	262	287	272	405	315	280	155	250	355	250	355
PV-L 40	356	284	314	293	450	340	302	170	280	375	280	375
PV-L 45	393	313	350	319	490	375	335	190	300	400	300	400
PV-L 50	436	345	386	350	546	410	370	211	335	450	335	450
PV-L 56	488	393	438	392	613	460	418	238	375	500	375	500
PV-L 63	545	440	493	438	688	515	472	263	425	560	425	560

Dimensioni in mm / Dimensions in mm

BOCCA ASPIRANTE / INLET

TIPO / TYPE	Øn	Øi	p	Øm
PV-L 352	185	219	8	8
PV-L 382	205	241	8	8
PV-L 402	205	241	8	8
PV-L 452	228	265	8	8
PV-L 502/A	255	292	8	10
PV-L 502/B	255	292	8	10
PV-L 552	285	332	8	10
PV-L 562	285	332	8	10
PV-L 632	320	366	8	10

Dimensioni in mm / Dimensions in mm

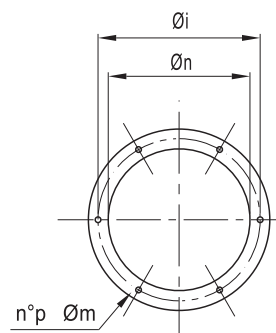

BOCCA PREMENTE / OUTLET

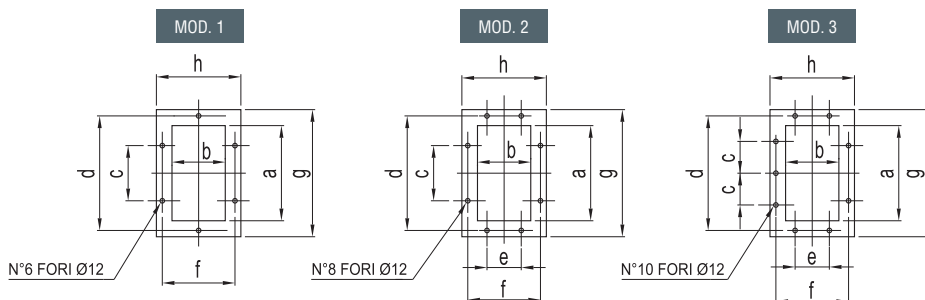

TIPO / TYPE	a	b	c	d	e	f	g	h	Mod.
PV-L352	146	105	112	182	-	139	216	175	1
PV-L 382	166	117	112	200	-	151	236	187	1
PV-L 402	166	117	112	200	-	151	236	187	1
PV-L 452	185	131	112	219	-	165	255	201	1
PV-L 502/A	207	148	112	241	112	182	277	218	2
PV-L 502/B	207	148	112	241	112	182	277	218	2
PV-L 552	231	166	112	265	112	200	301	236	2
PV-L 562	231	166	112	265	112	200	301	236	2
PV-L 632	258	185	112	292	112	219	328	255	3

Dimensioni in mm / Dimensions in mm