



DESCRIZIONE GENERALE

I ventilatori centrifughi della serie DIC sono adatti per il convogliamento d'aria pulita e fumi non polverosi, fino alla temperatura massima di 80°C. Trovano il loro impiego in tutte quelle applicazioni industriali dove siano richiesti piccoli volumi d'aria con alte pressioni. La serie è costituita da modelli con diametro girante da 100 a 180 mm. Il motore è direttamente accoppiato alla girante del tipo pale avanti. La cassa è facilmente orientabile, anche in sito, ogni 45°, compresi gli angoli 180° e 225°. È disponibile la versione antideflagrante DIC-ATX costruita e certificata in conformità alla Direttiva ATEX 94/9 CE ed il suo impiego è previsto con aria pulita -10°C / +40°C. Tali serie sono adatte all'installazione in zona 1/21, cioè in aree o ambienti dove sia necessario garantire un elevato fattore di sicurezza contro le esplosioni, dovuti a gas (IIG) e/o polveri infiammabili (IIGD/IIGD). Questi apparecchi sono certificati da Ente Notificato secondo la norma 94/9 CE.

COSTRUZIONE

- Cassa a spirale realizzata in lamiera d'acciaio. Protetta contro gli agenti atmosferici con vernici a polveri epossipoliestiriche.
- Girante a semplice aspirazione, realizzata in lamiera zincata con pale curve in avanti (sirocco), a spessore costante.
- Esecuzione 5, (accoppiamento diretto con girante a sbalzo su motore flangiato).
- Orientamento standard LG 270°.
- Motorizzazioni:
 - DIC: motore asincrono trifase o monofase a norme internazionali IEC 60034, IEC 60072, EMC 2004/108/CE, LVD 2006/95/CE e marcato CE IP55, classe F, forma B35. DIC 100 T e M con motore forma B14, IP44, classe B.
 - DIC-ATX: motore asincrono trifase o monofase IIG, IIGD, IIGD a norme internazionali IEC 60034, IEC 60072, IEC 60079 e/o IEC 61241, EMC 2004/108/CE, LVD 2006/95/CE, con certificati ATEX e marcatura CE, IP 55/IP 65, classe F, forma B35. Tutti idonei ad un servizio S1 (funzionamento continuo a carico costante).

ACCESSORI

- Rete di protezione per bocca aspirante e premente realizzata a norma UNI 10615 e protetta contro gli agenti atmosferici.
- Supporto portamotore, realizzato in lamiera verniciata con vernici a polveri epossipoliestiriche.

A RICHIESTA

- DIC 100 con motore asincrono trifase o monofase a norme internazionali IEC 60034, IEC 60072, EMC 2004/108/CE, LVD 2006/95/CE e marcato CE IP55, classe F, forma B35 (DIC 100 MEC).
- Rotazione RD a richiesta.
- Versione resistente all'azione corrosiva del fluido trasportato, realizzata con cassa, flange e girante in acciaio inossidabile AISI 304 (DIC-INOX) - vedere sezione 10.
- Versione idonea al trasporto di gas caldi, max 150°C (DIC-AT).

INSTALLAZIONE

I ventilatori centrifughi con girante a pale curve in avanti devono sempre funzionare collegati a tubazioni o prevedere sistemi, che con la loro resistenza (ad esempio serrande di taratura), ne limitino la portata in modo tale che i valori di corrente assorbita rientrino nei valori ammissibili riportati sulla targa del motore elettrico.

GENERAL DESCRIPTION

The centrifugal fans of the DIC series are designed to convey clean and not-dusty air and smoke, up to a maximum temperature of 80°C. They are suitable for all the industrial applications where small air volumes and high pressures are required. The series consists of different models with impeller diameter from 100 to 180 mm. The motor is directly fitted to the forward curved impeller. The casing is easily adjustable, also on site, to the required discharge angle every 45°, including 180° and 225° position. The explosion-proof version DIC-ATX is certified by a Notified Body according to the 94/9/CE Atex Directive and is suitable to convey clean air in the temperature range -10°C +40°C. This version is suitable for installation in zone 1/21, that are areas where it is necessary to guarantee high security against explosions and fires due to presence of flammable gas(IIG) and/or dusts (IIGD/IIGD).

CONSTRUCTION

- Volute casing in steel sheet, protected against atmospheric agents by epoxy paint.
- Single inlet, single width, forward curved impeller (sirocco type), in galvanized steel sheet.
- Execution 5 (with impeller directly coupled to flanged motor)
- Standard orientation LG270°.
- Motorizations:
 - DIC: asynchronous three-phase or single-phase motors according to international standards IEC 60034, IEC 60072, EMC 2004/108/CE, LVD 2006/95/CE, CE marked, IP 55, class F, B35 shape. DIC 100 T and M with motor shape B14, IP44, class B.
 - DIC-ATX: asynchronous three-phase motors or single-phase IIG, IIGD, IIGD according to international standards IEC 60034, IEC 60072, IEC 60079 and/or IEC61241, EMC 2004/108/CE, LVD 2006/95/CE, with Atex certification, CE marked, IP55/IP 65, class F, B35 shape.
 - All motors suitable to S1 service (continuous working at constant load).

ACCESSORIES

- Inlet and outlet protection guard according to UNI 10615 rules and protected against atmospheric agents.
- Motor support in steel sheet epoxy painted.

UPON REQUEST

- DIC 100 with asynchronous three-phase or single-phase motors according to international standards IEC 60034, IEC 60072, EMC 2004/108/CE, LVD 2006/95/CE, CE marked, IP 55, class F, B35 shape (DIC 100 MEC).
- Rotation RD upon request.
- Corrosion resistance version, with casing, flanges and impeller in stainless steel AISI 304 (DIC-INOX) see section 10.
- Version suitable to convey hot gases, up to 150°C maximum (DIC-AT).

INSTALLATION

The centrifugal fans with forward curved impellers must always be installed to ducted systems, eventually with the use of additional resistance (for example setting shutters), that can limit the air flow in such a way that the absorbed current is within the acceptable values stated on the motor rating label.



Frequenza 50Hz – Temperatura dell'aria 15°C – Pressione barometrica 760 mm Hg – Peso specifico dell'aria 1,22 Kg/m³
 Frequency 50Hz – Air temperature 15°C – Barometric pressure 760 mm Hg – Air specific weight 1,22 Kg/m³

Lp: livello di pressione sonora rilevato a 1,5 m - **Lp**: sound pressure level measured at 1,5 m

DIC 100							
Tipo Type	Modello Model	U	P	Pm (kW)	In (A)	IP/CL	Lp dB(A)
DIC	100/2	M	2	0,05	0,36	44/B	59
DIC	100/2	T	2	0,05	0,17	44/B	59
DIC - ATX	100/2	M	2	0,06	1,20	55/F	59
DIC - ATX	100/2	T	2	0,09	0,35	55/F	59

Limiti d'impiego - Operational limit							
Tipo Type	Modello Model	Q max (m ³ /h)	Pt min (mm H2O)	C max (m/s)	S (m ²)	Pd ² (kgm ²)	Mot. (Gr)
DIC	100/2	305	11	13,31	0,006384	0,0016	50

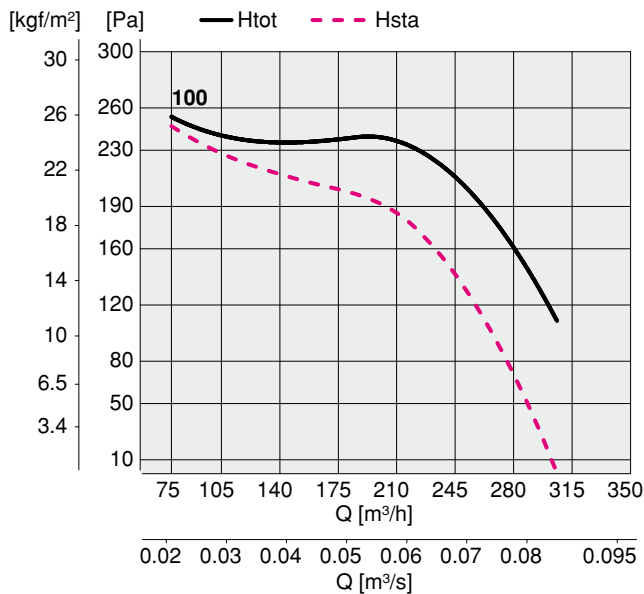

DIC 120							
Tipo Type	Modello Model	U	P	Pm (kW)	In (A)	IP/CL	Lp dB(A)
DIC	120/2	M	2	0,25	1,70	55/F	63
DIC	120/2	T	2	0,25	0,78	55/F	63
DIC - ATX	120/2	M	2	0,25	2,20	55/F	63
DIC - ATX	120/2	T	2	0,25	0,82	55/F	63

Limiti d'impiego - Operational limit							
Tipo Type	Modello Model	Q max (m ³ /h)	Pt min (mm H2O)	C max (m/s)	S (m ²)	Pd ² (kgm ²)	Mot. (Gr)
DIC	120/2	790	28	21,14	0,010404	0,0036	63

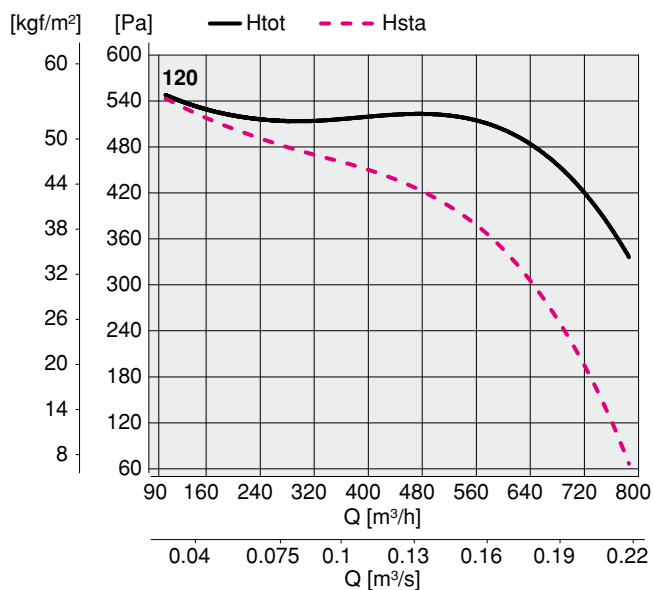

DIC 140							
Tipo Type	Modello Model	U	P	Pm (kW)	In (A)	IP/CL	Lp dB(A)
DIC	140/2	M	2	0,37	3,00	55/F	70
DIC	140/2	T	2	0,37	1,00	55/F	70
DIC - ATX	140/2	M	2	0,37	2,50	55/F	70
DIC - ATX	140/2	T	2	0,37	0,97	55/F	70

Limiti d'impiego - Operational limit							
Tipo Type	Modello Model	Q max (m ³ /h)	Pt min (mm H2O)	C max (m/s)	S (m ²)	Pd ² (kgm ²)	Mot. (Gr)
DIC	140/2	1025	26	20,50	0,013924	0,0064	71

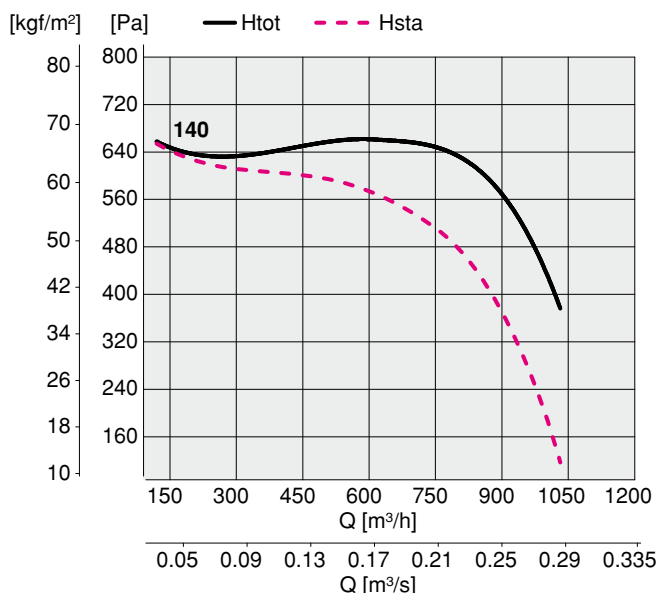



Frequenza 50Hz – Temperatura dell'aria 15°C – Pressione barometrica 760 mm Hg – Peso specifico dell'aria 1,22 Kg/m³
 Frequency 50Hz – Air temperature 15°C – Barometric pressure 760 mm Hg – Air specific weight 1,22 Kg/m³

Lp: livello di pressione sonora rilevato a 1,5 m - **Lp:** sound pressure level measured at 1,5 m

DIC 160							
Tipo Type	Modello Model	U	P	Pm (kW)	In (A)	IP/CL	Lp dB(A)
DIC	160/2	M	2	0,75	5,20	55/F	75
DIC	160/2	T	2	0,75	1,90	55/F	75
DIC - ATX	160/2	T	2	0,75	1,73	55/F	75

Limiti d'impiego - Operational limit							
Tipo Type	Modello Model	Q max (m ³ /h)	Pt min (mm H2O)	C max (m/s)	S (m ²)	Pd ² (kgm ²)	Mot. (Gr)
DIC	160/2	1385	81	21,16	0,018225	0,0104	80

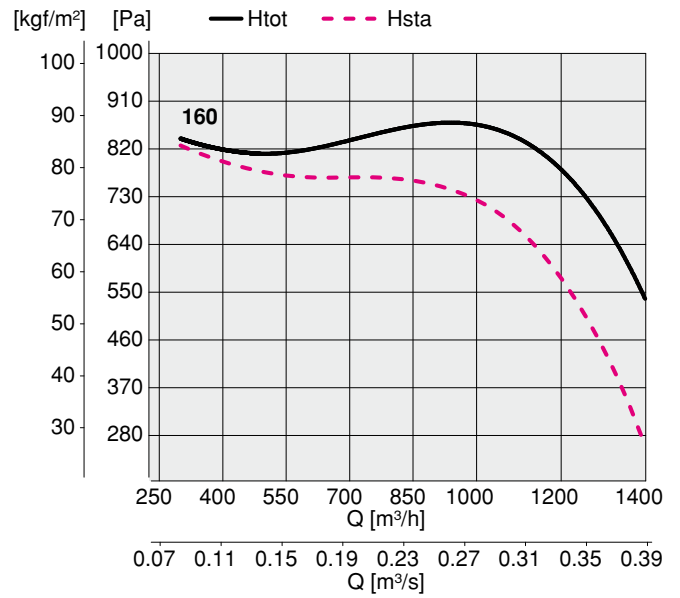

DIC 180							
Tipo Type	Modello Model	U	P	Pm (kW)	In (A)	IP/CL	Lp dB(A)
DIC	180/2	T	2	1,10	2,80	55/F	76
DIC - ATX	180/2	T	2	1,10	2,50	55/F	76

Limiti d'impiego - Operational limit							
Tipo Type	Modello Model	Q max (m ³ /h)	Pt min (mm H2O)	C max (m/s)	S (m ²)	Pd ² (kgm ²)	Mot. (Gr)
DIC	180/2	1520	97	19,29	0,021904	0,02	80

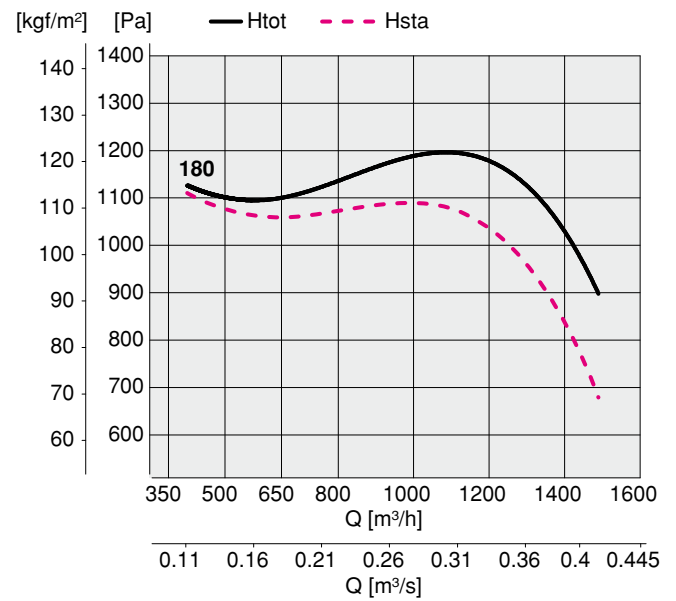

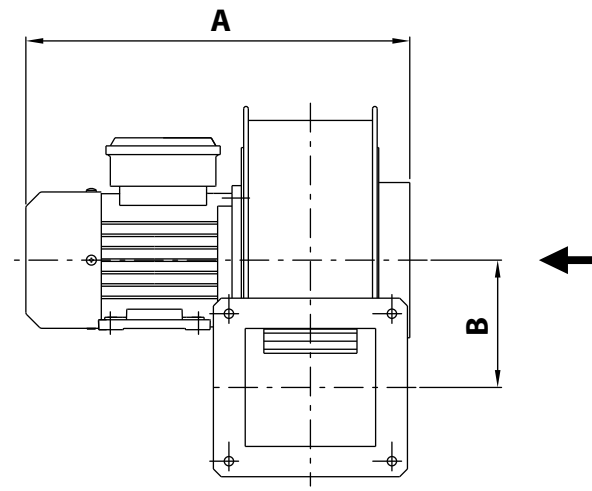
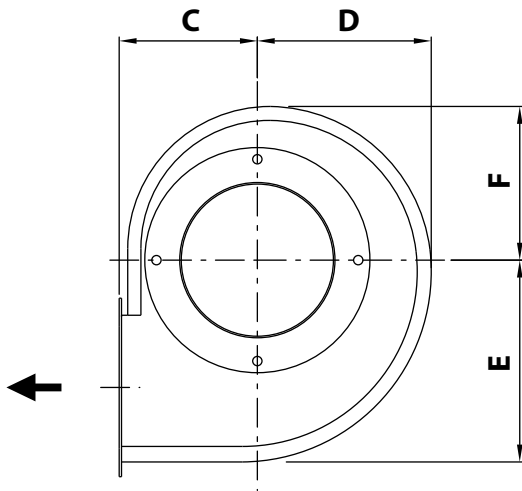

TIPO TYPE	A	B	C	D	E	F	a	b	c	d	e	f	g	h	i	l	m	n	kg
DIC 100	300	82	89	112	130	99	76	84	105	95	115	125	6	20	4	6	130	100	4
DIC 120	360	97	102	137	156	116	102	102	125	125	150	150	7	20	4	6	160	125	7
DIC 140	420	115	123	158	184	136	118	118	148	148	175	175	8	30	4	6	180	125	10
DIC 160	460	132	143	175	207	148	135	135	165	165	195	195	8	40	8	6	222	160	17
DIC 180	475	140	152	200	227	171	148	148	180	180	210	210	8	40	8	6	222	160	17

Dimensioni in mm / Dimensions in mm

sez. **5**
pag. 5

BOCCA ASPIRANTE / INLET

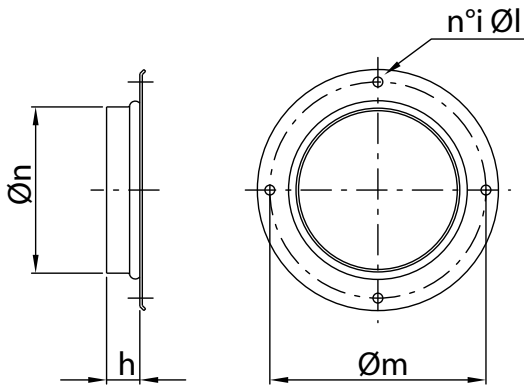

TIPO TYPE	Øn	h	Øm	i	Øl
DIC 100	100	20	130	4	6
DIC 120	125	20	160	4	6
DIC 140	125	30	180	4	6
DIC 160	160	40	222	8	6
DIC 180	160	40	222	8	6

Dimensioni in mm / Dimensions in mm

BOCCA PREMENTE / OUTLET

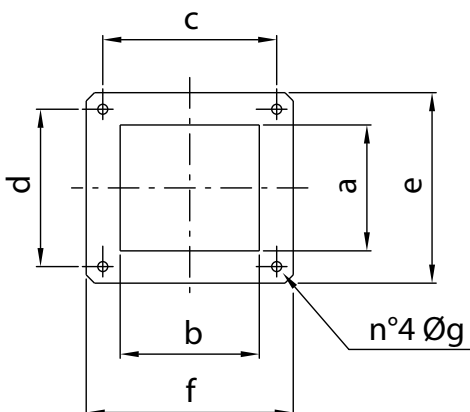

TIPO TYPE	a	b	c	d	e	f	g
DIC 100	76	84	105	95	115	125	6
DIC 120	102	102	125	125	150	150	7
DIC 140	118	118	148	148	175	175	8
DIC 160	135	135	165	165	195	195	8
DIC 180	148	148	180	180	210	210	8

Dimensioni in mm / Dimensions in mm

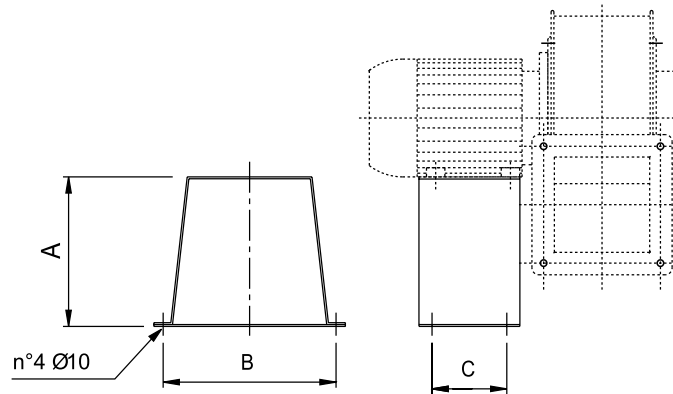
**SEDIA PORTAMOTORE / MOTOR SUPPORT**

TIPO / TYPE	A	B	C	Kg
100	120	140	71	0,5
120	160	185	80	1
140	152	185	80	2
160 - 180	180	230	100	2,5

Dimensioni in mm / Dimensions in mm

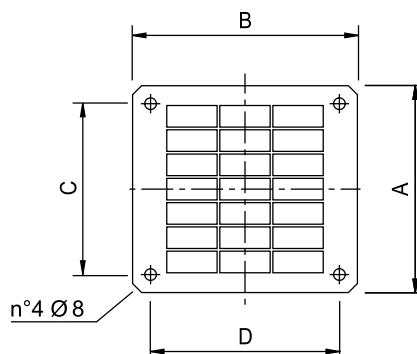
RETE BOCCA PREMENTE / OUTLET GUARD

TIPO / TYPE	A	B	C	D	Kg
100	115	125	95	105	0,06
120	150	150	125	125	0,12
140	175	175	148	148	0,13
160	195	195	165	165	0,15
180	210	210	180	180	0,2

Dimensioni in mm / Dimensions in mm

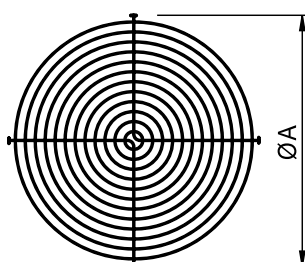
RETE BOCCA ASPIRANTE / INLET GUARD

TIPO / TYPE	ØA	Kg
100	115	0,06
120 - 140	150	0,12
160 - 180	195	0,15

Dimensioni in mm / Dimensions in mm